



A DECADE OF INNOVATION

A Legacy of Excellence

30 May - 1 June 2024

HITEX, Hyderabad

SHOW DIRECTORY 2024





FILTROMIX
EQUIPMENTS LLP

Multi-process Equipment-plough Shear Mixer

WE HAVE DELIVERED PLOUGH SHEAR MIXER AS PLOUGH VACUUM DRYER WITH SPECIALLY DESIGNED BLADES TO CUT LUMPS FORMED AFTER DRYING FOR API IN GMP MODEL NUTRACEUTICAL & EXCIPIENT

- ◆ Powder - Powder Mixing
- ◆ Powder - Liquid Mixing
- ◆ Homogenising
- ◆ Blending
- ◆ Wet Granulation
- ◆ Multiple Phase Reaction
- ◆ Solid-Liquid-Gas Pressure/Vacuum
- ◆ Drying/vacuum drying

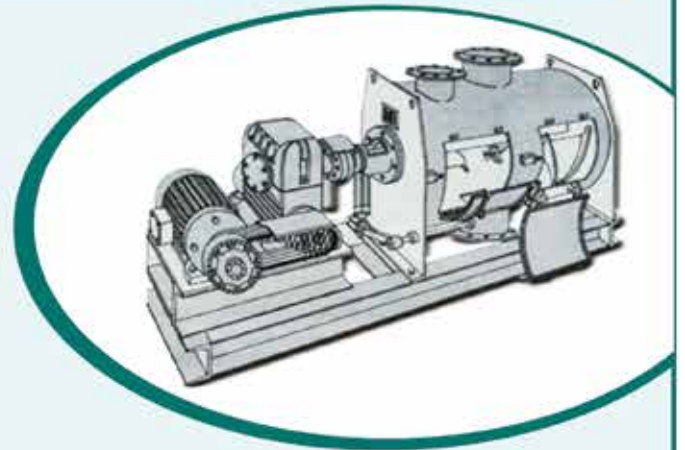

Unit No. 3, ACME Industrial Park, Near W.E. Highway, I.B. Patel Road, Goregaon (E), Mumbai-400063.

Tel.: +91-9821354747 / +91-9819272916

Email: filtromix@hotmail.com / harsh.shah@filtromix.com

Web.: www.filtromix.com

MD's Message.....	4
Conference Agenda	5
Speaker Profile.....	12
Exhibitor List.....	15
Floor Plan	19
Exhibitor Profile.....	22

MD's Message

I am delighted to welcome you to the landmark 10th edition of PharmaLytica Expo 2024, taking place from May 30th to June 1st, 2024, at the HITEX, Hyderabad.

As the flagship event within South India's pharmaceutical industry, the PharmaLytica Expo is celebrating a decade long journey of excellence in providing a vital business platform for showcasing the latest industry trends, innovations, and business opportunities across Pharma Machinery & Packaging, Lab Analytical & Cleanroom, and Pharma Ingredients segments.



The Indian pharmaceutical and healthcare sectors are experiencing remarkable growth, driven by innovation, global supply chain integration, and initiatives like the National Policy on Research and Development and Innovation in the Pharma-MedTech Sector and the Ayushman Bharat programme. This growth is further supported by substantial governmental spending on pharmaceuticals, including an increase of 12.6 percent in the interim Budget this year and the allocation of Rs. 1,000 crores for promoting bulk drug parks in FY25.

Under the vital umbrella of expos such as PharmaLytica, ideas flourish and businesses thrive, driving progress within the pharmaceutical landscape,

This year, the event anticipates the participation of over 200 exhibitors showcasing more than 1000 brands, offering a content-rich conference, and abundant networking prospects. With a targeted professional audience keen to elevate the Indian pharma market to the next level of growth, PharmaLytica Expo 2024 promises to be an unparalleled opportunity for industry leaders, innovators, and stakeholders to explore the forefront of India's thriving pharmaceutical landscape.

Key industry players such as Schneider Electric, Integrated Cleanroom Technology, Nicomac Taikisha Clean Rooms, HLE Glascoat Ltd, Scientific Research Instruments Company, and Ami Polymer, among many others, will be showcasing their latest innovations and solutions. Supported by esteemed associations like BDMAI, FOPE, and Telangana Life Sciences, PharmaLytica Expo 2024 is set to be a comprehensive and engaging event.

As part of the Expo, an exclusive two-day conference with the theme "Optimizing Pharmaceutical Quality and Compliance" will bring together over 30 key industry figures for strategic discussions on the future of the pharmaceutical sector. With renowned industry speakers and insightful discussions, PharmaLytica Expo 2024 ensures valuable networking opportunities and knowledge exchange.

On behalf of Informa Markets in India, I extend a warm welcome to each of you, and I wish you a fruitful and enriching experience in this year's edition.

Best wishes,

Yogesh Mudras

Managing Director

Informa Markets in India

Conference Agenda

PharmaLytica 2024, May 30-31, 2024, HITEX, HYDERABAD, INDIA

DAY 1 – 30th MAY 2024

09:00 - 10:00	Registration & Networking
10:00 - 11:00	Welcome Address and Conference Inauguration

TECHNOLOGY TRENDS

11: 00 - 11:50	<p>PANEL DISCUSSION - MAXIMIZING PHARMA PRODUCTIVITY THROUGH TECHNOLOGICAL ADVANCEMENT</p> <ul style="list-style-type: none">• Optimizing formulation process by implementing process analytical technology (PAT) solutions, continuous manufacturing techniques and big data analytics• Leveraging AI tools for accelerating drug discovery and development• Integrating data analytics tools, advanced spectroscopic and chromatographic techniques for rapid raw material characterization and quality assurance, ensuring consistency and purity• Leveraging predictive analytics and AI-driven demand forecasting to optimize inventory, mitigate stock outs, and prevent supply chain disruptions• Deploying IoT sensors and blockchain technologies to offer real-time pharmaceutical raw material and finished product tracking and traceability <p>MODERATOR: GIRISH KAPUR, Senior Vice President & Site Head, R&D, US Pharmacopeia - India</p> <p>PANELIST : DR. SURESH PATHI, Head Operational Excellence-Formulation Cluster, Granules India DR. KRISHNA BHAVANASI, Chief Scientific Officer, Extrovis Pharma DR. DAMODHARAN MUNIYANDI, Chief Quality Officer - Global Quality & Regulatory Affairs, Sai Lifesciences GOPAL MADABHUSHI, Senior Vice President Business Leader - South Asia, Veolia Water Technologies and Solutions.</p>
11: 50 -12:20	<p>THE ROLE OF INDIAN PHARMACOPEIA COMMISSION IN SETTING PHARMACOPEIAL STANDARDS</p> <ul style="list-style-type: none">• Identifying the process for setting Indian Pharmacopoeia (IP) monograph standards• Role in ensuring the quality of medicines• Establishment of IP reference standards• Harmonization of pharmacopoeia standards, and global recognition of the IP• DR. GAURAV PRATAP SINGH, Senior Principal Scientific Officer, Indian Pharmacopoeia Commission

Conference Agenda

TECHNOLOGICAL ADVANCEMENTS

12-20 -12:40	<p>AI/ML SOLUTION FOR API MANUFACTURING PROCESS – THE NEXT GEN PREDICTION SOLUTION</p> <ul style="list-style-type: none">• How to develop and train an AI/ML model in a sequential structure• Convert unstructured data to structured data• Create data lake• Compare the data at one place• Apply statistical tools• Train the ML model.• Generate predictions• How AI/ML model can predict the potential failures in manufacturing process. A practical case study. <p>DR. DAMODHARAN MUNIYANDI, Chief Quality Officer - Global Quality & Regulatory Affairs, Sai Lifesciences</p> <p>RAJENDRA LAKSHMI PRASAD, Head Data Analytics, Sai LifeSciences</p>
12:40 - 01:00	<p>TECHNOLOGY EVOLUTION IN PHARMA WATER/WASTEWATER MANAGEMENT</p> <ul style="list-style-type: none">• Sustainable, low OPEX Cold WFI for injectables/vaccines• Advanced biological treatment for micropollutant/AMR removal• Power driven “Steam free” compact ZLDs <p>SANTHOSH HEGDE, Sales Leader - South Asia, Veolia Water Technologies and Solutions.</p>

BIOSIMILAR

01:00 - 01:15	<p>REGULATORY AND QUALITY FRAMEWORK OF BIOSIMILARS DEVELOPMENT</p> <ul style="list-style-type: none">• Biosimilars play a vital role in increasing the accessibility of Biologics drugs• Extensive analytical studies are essential to establish similarity with originator products• Critical clinical studies are needed to establish safety and efficacy of Biosimilars <p>DR. RANJAN CHAKRABARTI, Consultant, Biopharma and Drug Discovery</p>
01:15 – 02:00	<p>LUNCH & NETWORKING</p>

Conference Agenda

DRUGS REPOSITIONING STRATEGIES

02:00 - 02:20	FIRESIDE CHAT: MAXIMIZING DRUG REPOSITIONING: INDIA'S STRATEGIC APPROACH TO EXPLORING NEW THERAPEUTIC APPLICATIONS <ul style="list-style-type: none">• Insights from Case Studies like Remdesivir etc.• Benefits of drug repositioning and identifying potential drugs for repurpose• Integrating AI into Drug Repositioning Strategies, approaches methods and consideration• Identifying opportunities for cross-sector partnerships and data sharing• Understanding regulatory frameworks to support and facilitate drug repositioning MODERATOR: NALAM MADHUSUDHANA RAO , CEO, Atal Incubation Centre -CCMB, Hyderabad PANELIST: DR. TATHAGATA DUTTA , Chief Technology Officer, JODAS EXPOIM Pharmaceuticals DR. SRINIVAS ARUTLA , Chief Executive Officer, Zenara Pharma
----------------------	---

QUALITY INTEGRATION IN CLINICAL DEVELOPMENT

02:20 - 02:40	QUALITY EXCELLENCE IN CLINICAL TRIALS <ul style="list-style-type: none">• Quality centric approach in clinical trials- CRO, sponsor and ICH-GCP• Audits and inspection readiness in clinical trials• Automation in Clinical quality processes Dr. Shubhadeep D Sinha , Senior Vice President Development, Hetero Group of Companies (Hetero Labs)
----------------------	--

PHARMA PACKAGING

02:40 - 03:30	PANEL DISCUSSION: ADAPTING TO EVOLVING PHARMACEUTICAL PACKAGING STANDARDS <ul style="list-style-type: none">• Understating revised chapters USP 661 and 671 compliance and decoding revisions and Strategies to prepare for and adapt to the revised USP standards ahead of the 2025• Overview on technology advancements and how it is facilitating compliance with evolving standards, such as tamper-evident features, serialization, and smart packaging solutions• Importance of adapting packaging practices to ensure product safety and integrity, addressing concerns such as counterfeit drugs, contamination, and shelf-life extension.• Growing importance of sustainable packaging solutions in the pharmaceutical industry and how companies are integrating eco-friendly materials and practices to reduce environmental impact• Insights into future trends and advancements in developing flexible and responsive packaging solutions to anticipate regulatory changes and market needs MODERATOR: RAVIPATI CHANDI PRASAD , Head Packaging Development, Aurobindo Pharma Ltd. PANELIST: SEKHAR BABU PULI , Head - Packaging Development, MSN Laboratories RAM GOPAL , DGM Packaging Development, Aurobindo Pharma
----------------------	---

03.30 – 04.00	Tea - Coffee and Networking Break
----------------------	--

Conference Agenda

BIO-PHARMA STARTUP

04:00 – 04:20

ROLE OF INCUBATORS IN NURTURING BIO-PHARMA STARTUPS TO SCALE-UP

- Understating the need for Biopharma Startup Incubation
- Overview of Pilot or Scale-up avenues
- Understanding application processes and eligibility criteria for Government Grants and Subsidies and Overview of different funding opportunities

RAMJEE PALLELA, Chief Operating Officer, **Atal Incubation Centre-CCM**

ANALYTICAL INSTRUMENTATION

04:20 - 04:45

RECENT DEVELOPMENTS IN ICH GCP E6 R2

- History of ICH GCP
- Evolution of GCP
- Need for new guidance post pandemic situation
- Way forward to ICH GCP

DR. PANKAJ THAKUR, General Manager, **Hetero Labs**

DAY 2 – 31st MAY 2024

API

11:00 -12:00

PANEL DISCUSSION :- SHIFTING THE GEAR: STRATEGIES FOR INDIA'S TRANSITION FROM GENERIC MANUFACTURER TO API PRODUCTION HUB

- Analyzing the need for shifting focus to API manufacturing
- Identifying the innovative approaches and technologies to optimize API manufacturing processes and reduce production costs
- Role of emerging technologies such as continuous manufacturing, green chemistry, and process automation to improve efficiency, sustainability, and cost-effectiveness
- Outlining the regulatory hurdles and propose solutions for streamlining processes
- Exploring opportunities for global collaboration, partnerships, and market access agreements to promote India's API manufacturing capabilities globally
- Control strategies in complex API manufacturing

MODERATOR: SIVAKUMAR V, DIRECTOR, PharmQS Consulting (**Former Quality Lead in Pfizer & Mylan**)

PANELIST:

RAMKUMAR ESAKKI, Senior Vice President, **Suven Pharma**

BALARAM PATRO, CEO, **GRK Research Laboratories**

DR. VASANTHAKUMAR RAMU, Head of Research and Development - Peptides & Complex, API's, **Alembic Pharmaceuticals**

HIMAL P. DESAI, Executive Vice President, Supply Chain Management & Information Technology, **Sekhmet Pharmaventures**

MATRUPRASAD P, Senior Director - Regions & Program Operations & General Manager - South Asia, **US Pharmacopeia**

Conference Agenda

CRO AND CMO

12:00 - 12:20	<p>REDEFINING PHARMA PARTNERSHIPS: MAXIMIZING VALUE THROUGH STRATEGIC COLLABORATIONS WITH CMOs AND CROs</p> <ul style="list-style-type: none">• Understanding the dynamics of outsourcing in pharma• The rise of sophisticated CMOs and CROs with focus on their core competencies of drug discovery and development• Strategies for managing outsourcing relationships, mitigating potential challenges, and leveraging opportunities for growth <p>KIRAN MARTHAK, Director - Medical Affairs, Phase-1 and Regulatory Affairs, Veeda Clinical Research</p>
---------------	--

PHARMA MANUFACTURING

12:20 - 12:40	<p>EMPOWERING PHARMA MANUFACTURING WITH ADVANCED ANALYTICS</p> <ul style="list-style-type: none">• A data driven approach by Quality-by-Design (QbD) in continuous manufacturing• Role of advanced analytics in meeting regulatory standards• Optimizing ISA-88 Standards for batch control and leveraging advanced techniques for monitoring vital process parameters and detecting deviations <p>RAMKUMAR ESAKKI, Senior Vice President, Suven Pharma</p>
---------------	--

INNOVATION

12:40 - 01:30	<p>PANEL DISCUSSION: BREAKING BOUNDARIES WITH INNOVATIONS IN PHARMACEUTICAL</p> <ul style="list-style-type: none">• AI, Big Data and advanced analytics optimizing personalized medicine and patient-centric care and revolutionizing drug discovery• Data analytics tool forecasting tomorrow's medicines today• Analytics driving pharma efficiency streamlining regulatory processes, accelerate approvals, and bring life-saving therapies to market faster• Blockchain & IoT paving the way for a future of unprecedented discovery and impact• Need for robust collaboration catalysts from industry leaders, researchers, and regulatory agencies to foster innovation and drive collective progress <p>MODERATOR: DR. SUBHASH THULUVA, Sr. Vice President & Head - Clinical Development, Biological E. Limited</p> <p>PANELIST:</p> <p>DR. SHUBHADEEP D SINHA, Senior Vice President Development, Hetero Group of Companies (Hetero Labs)</p> <p>ELAYARAJA NATARAJAN, Vice President - Research And Development, Lyrus Life Sciences</p> <p>AMAN AGARWAL, Head - Digital & Analytics for Manufacturing & Quality, Dr Reddy's Laboratories</p> <p>PRAVEEN KUMAR, Senior Director, Centralized Monitoring & Medical Data Review, Fortrea</p>
---------------	---

01:30 - 02:30	LUNCH NETWORKING BREAK
---------------	-------------------------------

GREEN CHEMISTRY

02:30 - 02:50	<p>FLOWING TOWARDS GREENER PHARMA: SUSTAINABLE PRODUCTION WITH FLOW CHEMISTRY</p> <ul style="list-style-type: none">• Significance of sustainability in the pharmaceutical industry and how flow chemistry differs from traditional batch processes• Advancements and innovations in flow chemistry to address sustainability goal• Call to action for continued research and collaboration to drive sustainable practices in the pharmaceutical industry <p>DR. MAKARAND PIMPLAPURE, Managing Director, MakSpeed Technologies</p>
02:50 - 03:10	<p>LEAN & AGILE SUPPLY CHAIN: RISK & CHALLENGES</p> <ul style="list-style-type: none">• Benefits of lean supply chain• Challenges of Lean supply chain risk management• Efficient supply chain Models <p>DEEPAK KHURANA, Vice President-Procurement & SCM, Suven Pharmaceutical</p>

ANALYTICAL INSTRUMENTATION

03:10 - 03:30	<p>EXPLORING CUTTING-EDGE TECHNOLOGIES REVOLUTIONIZING DRUG DISCOVERY, FORMULATION, AND QUALITY CONTROL</p> <ul style="list-style-type: none">• Role of advanced analytics optimizing personalized medicine• Leveraging analytics to streamline regulatory processes, accelerate approvals, and bring life-saving therapies to market faster• Reducing the complexities of data governance, quality assurance, and regulatory standards with big data <p>KAMARAJ ABRAHAM, Associate Vice President, Head Quality Assurance, Aurobindo Pharma</p>
---------------	---

03:30 - 04:00

TEA - COFFEE AND NETWORKING BREAK

SUPPLY CHAIN / COLD CHAIN

04:00 - 04:20	<p>BUILDING EFFICIENT PHARMA SUPPLY CHAIN AND COLD CHAIN ENHANCING QUALITY AND ACCESSIBILITY ACROSS PRODUCTION AND DISTRIBUTION</p> <ul style="list-style-type: none">• Designing efficient sustainable transportation practices to reduce carbon emissions and environmental impact• Developing robust uninterrupted cold chain quality management systems to monitor and maintain product integrity• Risk mitigation strategies and contingency planning and building resilience through diversification, redundancy, and flexibility in supply chain operations <p>Bharat Bhushan Rathi, Head Distribution and Logistics, Mankind Pharma</p>
---------------	--

Conference Agenda

INDUSTRY OUTLOOK- PHARMA PACKAGING, LABELLING, SERIALIZATION AND TRACK AND TRACE

04:20 - 04:40

ENSURING SAFETY AND SECURITY: PHARMA PACKAGING, LABELING, SERIALIZATION, AND TRACEABILITY SOLUTIONS

- Advancements in pharmaceutical packaging design and its role in ensuring the integrity of products throughout the supply chain
- Importance of accurate and compliant labeling practices focusing on strategies to improve patient safety, regulatory adherence, and information transparency
- Enhancing Supply Chain Visibility Through Serialization and Track & Trace

PV RAJU, Senior Vice President - Procurement & SCM, **Biological E**

04:40 - 05:00

VOTE OF THANKS

Speaker Profile



AMAN AGARWAL
Head - Digital & Analytics for
Manufacturing & Quality
Dr Reddy's Laboratories



BALARAM PATRO,
CEO,
GRK Research Laboratories



BHARAT BHUSHAN RATHI
Head Distribution and Logistics,
Mankind Pharma



DEEPAK KHURANA,
Vice President-Procurement &
SCM,
Suven Pharmaceutical



**DR. DAMODHARAN
MUNIYANDI,**
Chief Quality Officer - Global
Quality & Regulatory Affairs,
Sai Lifesciences



ELAYARAJA NATARAJAN,
Vice President - Research And
Development,
Lyrys Life Sciences



GIRISH KAPUR,
Senior Vice President & Site
Head, R&D,
US Pharmacopeia - India



GOPAL MADABHUSHI
Senior Vice President Business
Leader - South Asia,
Veolia Water Technologies and
Solutions



DR. GAURAV PRATAP SINGH,
Senior Principal Scientific Officer,
Indian Pharmacopoeia
Commission



HIMAL P. DESAI,
Executive Vice President,
Supply Chain Management
& Information Technology,
Sekhmet Pharmaventures



KAMARAJ ABRAHAM
Associate Vice President, Head
Quality Assurance
Aurobindo Pharma



DR. KIRAN MARTHAK,
Director - Medical Affairs,
Phase-1 and Regulatory Affairs,
Veeda Clinical Research



DR. KRISHNA BHAVANASI,
Chief Scientific Officer,
Extrovis Pharma



MATRUPRASAD P,
Senior Director - Regions &
Program Operations & General
Manager - South Asia,
US Pharmacopeia



**DR. MAKARAND
PIMPLAPURE,**
Managing Director,
MakSpeed Technologies



**NALAM MADHUSUDHANA
RAO,**
CEO,
Atal Incubation Centre
-CCMB, Hyderabad

Speaker Profile



DR PANKAJ THAKUR
General Manager,
Hetero Labs



PRAVEEN KUMAR
Senior Director, Centralized
Medical Data Review
Fortrea



PV RAJU,
Senior Vice President -
Procurement & SCM,
Biological



RAJENDRA LAKSHMI PRASAD
Manager, Head Data Analytics,
Sai LifeSciences



RAM GOPAL
DGM Packaging Development
& Monitoring
Aurobindo Pharma



RAMJEE PALLELA
Chief Operating Officer,
**Atal Incubation Centre-
CCM**



RAMKUMAR ESAKKI,
Senior Vice President,
Suven Pharma



DR. RANJAN CHAKRABARTI,
Consultant,
Biopharma and Drug Discovery



RAVIPATI CHANDHI PRASAD,
Head Packaging Development,
Aurobindo Pharma Ltd.

Speaker Profile



SANTOSH HEGDE
Sales Leader - South Asia
Veolia Water Technologies and
Solutions



SEKHAR BABU PULI,
Head - Packaging Development,
MSN Laboratories



SIVAKUMAR V,
Director, PharmQS Consulting
(Former Quality Lead
in Pfizer & Mylan)



DR. SHUBHADEEP D SINHA,
Senior Vice President
Development, **Hetero Group of
Companies (Hetero Labs)**



DR. SRINIVAS ARUTLA,
Chief Executive Officer,
Zenara Pharma



DR. SUBHASH THULVA,
Sr. Vice President & Head -
Clinical Development,
Biological E. Limited



DR. SURESH PATHI,
Head Operational Excellence-
Formulation Cluster,
Granules India



DR. TATHAGATA DUTTA,
Chief Technology Officer,
**Jodas Expoin
Pharmaceuticals**



DR. VASANTHAKUMAR RAMU,
Head of Research and
Development - Peptides &
Complex, API's,
Alembic Pharmaceuticals

Exhibitor List

Company name	Stand no
A S Automations	H21
A&D Instruments India (P) Ltd	M19
AGMEHRA Pvt Ltd	G18
Allyone Environmental Technologies India Pvt Ltd	D08
Alutech Packaging Pvt Ltd	L21
Ambetronics Engineers Pvt Ltd	G20
Ami Polymer Pvt Ltd	F08
Art Lab Equipments	C22
Asahi KASEI India Pvt Ltd	E25
ASAP INTERNATIONAL SDN BHD	K16
Atlanto Enterprises LLP	J20
Autocal Solutions Pvt Ltd	C19
Aztec Process Automation Pvt Ltd	B19
Badnaji & Sons	F21
Bioneau	J12
Bionex Process Equipment Pvt Ltd	E20
Bry-Air (Asia) Pvt Ltd	M21
Carewell Pharmapack International Pvt Ltd	A15
CM Pumps and Systems Pvt Ltd	G21
Compromec	G22
Control Print Limited	J21
Crozair Technicea Pvt Ltd	B02
DHV Fitting Pvt Ltd	G02
Ditap-V Automation Pvt Ltd	F16
Drystar India Pvt Ltd	E21
E+E Elektronik India Pvt Ltd	J15
Ezyprint Technologies	E19
Fermex Solutions LLP	A07
Fillpack Technology	A16
Filtromix Equipments LLP	A18
Fitwel industries LLP	A22
Foxx Life Sciences	H19
GAMP Services Pvt Ltd	M08
Gandhi Automations Pvt Ltd	C02
Getinge Medical India Pvt Ltd	L19

Exhibitor List

Company name	Stand no
Go Ezy Lift Tech Pvt Ltd	C16
GSS Engg Pvt Ltd	C08
Harikrushna Technopride Engg	H16
Hemochrom Ultrapure	M16
HLE Glascoat Ltd	K02
Hygro Tech Engineers	H15
Incep Bio	J22
Indo Rama Engineers	K19
Infionic	H17
Infozen India Enterprise	M17
Innovative Engineers HVAC Pvt Ltd	K20
Integrated Cleanroom Technology Pvt Ltd	L02
Ipsons Pharma	H12
Jain Steel Tube Co	A19
Jainex Electricals & Engineering Co	K17
Jetspray Innovations Pvt Ltd	M22
JOYAM ENGINEERS AND CONSULTANTS PVT LTD	D21
Jubilant Piping Solutions Pvt Ltd	C15
Kinam Engineering Industries Pvt Ltd	K02
Klimapharm Technologies Pvt Ltd	H03
KTT Pharmatech	I03
Labguard India Pvt Ltd	J02
Lennox Clean Air Technologies	H08
Lisaline Lifescience Technologies Pvt Ltd	I20
Lotus Technicals Pvt Ltd	H20
Lucky Deep Cleanroom Pvt Ltd	L14
Mahashakti Pharmamach	G19
MAK Engineers	E08
Masseprazise	L11
Mechmaark Filtech India Private Limited	K15
Meknetics innovations P Ltd	B16
MMP Industries Ltd	H22

Exhibitor List

Company name	Stand no
Moreschi Asia Doors Pvt Ltd	D12
MRB Forge & Fittings LLP	D11
Munters India Humidity Control Pvt Ltd	A12
Nanoprecise Data Services Pvt Ltd	L17
Network INC	I18
New Bio Scientific Company	L16
Nicomac Taikisha Clean Rooms Pvt Ltd	E02
Novasix Technologies pvt ltd	I04
Omega Scientific Instruments Pvt Ltd	I15
Origin Corporate Services Pvt Ltd	B12
Petals Engineers Pvt Ltd	L20
Pharma Spares Pvt Ltd	M12
Pharmacrux	G25
Pharmaffiliates Analytics & Synthetics (P) Ltd	B21
Polmon Instruments Pvt Ltd	F15
Pontos Labcare Pvt Ltd	C21
PR Pharma Engineers Pvt Ltd	B08
Prachi International	J16
Prasad Meditech	D19
Prime Care Technology Pvt Ltd	E15
Propack Technologies	H02
Raajratna Stainless Pvt Ltd	E22
Rafeeq Filtration Systems (3R Filters)	A01
Rahul Ferromet & Engineering Pvt Ltd	M02
Raindrop Aqua Solutions	L13
Ram Equipment	A11
Reynold India Pvt Ltd	L15
SG Pharmatec	B20
Sagar Air Pvt Ltd	I21
Sangama INC	K22
Schneider Electric India Pvt Ltd	D02
Scientific Devices (Bombay) Pvt Ltd	C12
Scientific Research Instruments Company Private Limited	I02

Exhibitor List

Company name	Stand no
Shah Brothers	K14
Shree Labware And Process Systems	M13
Shrirang Automations & Controls	F20
Sitriv Optronics Corporation	L22
Skytech Systems (I) Pvt Ltd	K21
SMS Instruments Pvt Ltd	B22
Spear Pack Pvt Ltd	G16
Spectrum Filtration PVT LTD	L12
Speed Seals Engineering	D20
Spoorthi Labeling Solutions Pvt Ltd	H25
SprypleHR - Attendance & Payroll Software	A21
Sunny Sterile Products	I22
Surravi Phharma	E18
Swathi Engineering Works	D16
Syntec Airflow System	G12
Technocrats	B17
Teknokroma India Pvt Ltd	F22
Tensil Labglass Technologies Pvt Ltd	C11
Testo India Private Limited	J08
Thaletec Gmbh	K02
Thermadyne Pvt Ltd	K12
Third Wave Ruggedtech Pvt Ltd	D15
Thorat Filtration Pvt Ltd	D25
TOPSE PROCESS SOLUTIONS PVT LTD	G15
UD Pharma Rubber Products	F19
ULTRAMAX HYDROJET PVT LTD	D22
Veolia Water Technologies and Solutions	C20
Vignan Instruments	E16
Vijay Rubber Products	J19
Vorx Industrial Solutions	M20
X2 Valves Pvt Ltd	I08
Yogi Kripa Steriprotek Packaging Pvt Ltd	M15



Nanoprecise
Prediction with Precision

IMPROVE MACHINE HEALTH AND ENERGY EFFICIENCY

BOOTH L17, HALL 4, PHARMALYTICA

**REDUCE
COSTS**

**AVOID
UNPLANNED
DOWNTIME**

**DRIVE
OPERATIONAL
EFFICIENCIES**

**REDUCE
CARBON
EMISSIONS**

**DELIVER
PEACE OF
MIND**

Learn more at nanoprecise.io

OASIS[®]

INDUSTRIAL LIGHTING SOLUTIONS

FLAMEPROOF
LIGHTS

CLEANROOM
LIGHTS

HIGHBAYS &
LOWBAYS



OUR CLIENTS



PHONE: +91 91675 22326

EMAIL: SALES@OASISLUMINAIRES.COM



Exhibitor Profile

A&D Instruments India (P.) Ltd.

Hall No - Hall4 **Booth No - M19**

Contact Person - L.K. Newseela

Address - D-48 Udyog Vihar, Phase-V,

City - Gurugram

State - Haryana

Zipcode - 122016

Country - India

Tel - 124 4715555

Email - info@aanddindia.in

Website - www.aanddindia.in

Description -

A&D Instruments India Private Limited (A&D India) a wholly owned subsidiary of A&D Company Limited Japan, setup its Sales and Technical Centre at Gurgaon, Haryana in the year 2008. A&D Company Limited, Japan is a world class producer of advanced measuring, monitoring, controlling and testing instruments. In India, we are responsible for promotion, sales and after sales services of A&D products like Electronic Weighing Balances & Scales, Viscometers, Moisture Analyzer, Indicators, Load cells, and Medical Products (Blood Pressure Monitors).

Product - Laboratory Products and Equipments, Purification and separation techniques, Testing and Measurement,

A.S. Automations

Hall No - Hall4 **Booth No - H21**

Contact Person - Sudhir Pangaonkar

Address - Plot no 122 Sector 7, PCNTDA, Bhosari, Pune

City - Pune

State - Maharashtra

Zipcode - 411026

Country - India

Tel - 9890198565

Email - asautomations@yahoo.com

Website - www.asautomations.com

Description -

Founded in 1999, A.S. Automations has ever since focused on developing innovative solutions for quality control on pharma packaging machines, strictly tailored to the specific needs and real practice demands as well as with economic aspects. Our continuous developments in instruments and processes ensure that the most modern technologies in electronics, optics and image processing are available. A.S. Automations offers a wide range of application specific and well-established detection systems for the control of pharmaceutical packaging. This range covers from simple control sensors to much complicated detection systems. We at A.S. Automations provide different tailor made automations.

Product - Packaging Equipment & Supplies, Process Automation & Controls

Allyone Environmental Technologies India Pvt. Ltd.

Hall No - Hall4 **Booth No - D08**

Contact Person - Rao Thakare

Address - B-239, Midc Malegaon Sinnar,

City - Nasik

State - Maharashtra

Zipcode - 422113

Country - India

Tel - 02551 230 061

Email - sales@allyone.co.in

Website - www.allyone.co.in

Description -

Reliable manufacturer and suppliers of Environmental Testing equipment to Pharmaceuticals, Chemicals, Research Institutes & Other industries Since Last 14 Years. We manufacture all our equipment's as per GMP/GEP/ ICH guidelines and also Confirms MCA & US FDA requirements. We care for customers and hence taken care of not only quality product but also Human and environment safety.

Product - Laboratory Products and Equipments, Machinery, QA & QC, Testing and Measurement,

Exhibitor Profile

Alutech Packaging Pvt. Ltd.

Hall No - Hall4 **Booth No - L21**

Contact Person - Anil Kumar Mittal

Address - 315, 3rd Floor, DLF Tower, Shivaji Marg,

City - New Delhi

State - Delhi

Zipcode - 110015

Country - India

Tel - 011 47098591

Email - anilk.mittal@alutechpackaging.com

Website - www.alutechpackaging.com

Description -

Alutech Packaging Pvt. Ltd. as one of the leading manufacturing companies of Aluminum based primary pharmaceutical packaging Products for solid oral doses situated in India. Our manufacturing facilities are located at Bahadurgarh (HR) and Nalagarh (HP).

Product - Packaging Equipment & Supplies,

Ambetronics Engineers Pvt. Ltd.

Hall No - Hall4 **Booth No - G20**

Contact Person - Ravi Shah

Address - 17-B Tarun Indl Estate New Nagardas Road Mogra Pada, Andhere (E)

City - Mumbai

State - Maharashtra

Zipcode - 400069

Country - India

Tel - 7718892211

Email - ravi@ambetronics.com

Website - www.ambertronics.com

Description -

Since 1992, Ambetronics Engineers Pvt. Ltd., led by Mr. Ashish Shah, stands as a paragon of excellence. Our TUV NORD certification underscores our steadfast dedication to quality. Renowned globally, our offerings include temperature and humidity monitoring, clean room and cold chain solutions, 21 CFR Part 11 compliant software, hydrogen gas detection for battery rooms, CO detection for underground parking, as well as gas detectors for various gases like H₂S, oxygen, and ammonia, along with flame detectors, gas monitors, analyzers, portable

detectors, and industrial automation solutions. Our commitment remains unwavering as we continue to deliver exceptional products and services.

Product - Clean Room Equipments, Health and Safety Products, Instruments, Process Automation & Controls,

Ami Polymer Pvt. Ltd.

Hall No - Hall4 **Booth No - F08**

Contact Person - Bharath Kumar Manne

Address - Plot No. 66-D/E, Govt. Industrial Estate Near Beekaylon Factory, Masat

City - Silvassa

State - Gujarat

Zipcode - 396230

Country - India

Tel - 95122 73732

Email - info@amipolymer.com

Website - www.amipolymer.com

Description -

Ami Polymer Pvt. Ltd. is one of the leading manufacturers and suppliers of Biopharmaceuticals and silicone-based products in India. Established in the year 1998, our company has been acclaimed for quality and excellence in the range of products offered. Our current manufacturing capacity is 25000 tonnes per month. We are equipped with testing facilities, R&D labs, CNC, VMC machines, and curing systems for quality products. We have delivered accuracy and finesse in over 5000 products tailor-made to over 3000 customers globally.

Product - Biotechnology, Capsules / encapsulation, Clean Room Equipments, Filling Equipments, Health and Safety Products, Packaging Equipment & Supplies, Tableting / Capsule fillers,

Exhibitor Profile

Art Lab Equipments

Hall No - Hall4

Booth No - C22

Contact Person - Rajya Laxmi

Address - Plot No.5L, Phase-V IDA Jeedimetla Medchal-Malkajgiri Dist

City - Hyderabad

State - Telangana

Zipcode - 500055

Country - India

Tel - 8332070125

Email - artlabsindia@gmail.com

Description - Laboratory furniture and fume hoods

Product - Laboratory Products and Equipments, Life Sciences, bulk drug, R&D labs, Colleges, Research labs,,

Atlanto Enterprises LLP.

Hall No - Hall4

Booth No - J20

Contact Person - Murtuza Lokhandwala

Address - 315,Tantia Jogani Industrial estate, Jr Boricha Marg, Saat Rasta, Mahalaxmi

City - Mumbai

State - Maharashtra

Zipcode - 400011

Country - India

Tel - 23000008

Email - atlantoent@gmail.com

Website - www.alantollp.com

Description -

ear 1975, a young mechanical engineer, with a distinction on his c.v., an insatiable mind and a fire in his heart embarks on a lifelong journey of commitment and breathes life to his dream project, 'Atlanto LLP'! With the motto of 'providing best quality products at reasonable prices and optimum after sales service, Atlanto LLP continues to surprise with new to newer innovations at optimizing growth. With this motto, we have been serving the pharmaceutical industry since the last 43 years and are pioneers of many innovative products, such as special static current passable sieve (S.C.P.S.TM) suitable for sifter

Product - Machinery,

Autocal Solutions Pvt. Ltd.

Hall No - Hall 4

Booth No - C19

Contact Person - Ronit Shirsat

Address - Unit no.4, Ruby Industrial Estate PCS Ltd, Navghar,

City - Vasai Road East

State - Maharashtra

Zipcode - 401210

Country - India

Tel - 8082426309

Email - ronit@autocal.in

Website - www.autocal.net

Description -

Autocal is India's top choice for Calibration, Validation and Testing service provider.

Product - Testing,

Aztec Process Automation Pvt. Ltd

Hall No - Hall 4

Booth No - B19

Contact Person - Bibek Pani

Address - TP House, 5th Floor, Jai Hind Enclave, Madhapur

City - Hyderabad

State - Telengana

Zipcode - 500081

Country - India

Tel - 7093500754

Email - bibek.pani@aztec-consult.com

Description -

About Aztec process automation Pvt Ltd Aztec is a process automation and information management firm with global presence. Aztec services range from industrial control and automation to enterprise systems and services including project management, design, implementation, and validation. Aztec is comprised of engineers with deep experience in process automation, specifically for batch manufacturing systems. Aztec Services: 1. Detailed Engineering 2. Validation and Qualification 3. Process Automation 4. Manufacturing Execution Systems (MES) 5. Process Historian & Data Analytics (OSI PI)

Exhibitor Profile

Bioneau

Hall No - Hall4

Booth No - J12

Contact Person - Arihant Jain

Address - 205, 2nd Floor, Near Hope Hospital, Lake hill road

City - HYDERABAD

State - TELANGANA

Zipcode - 500063

Country - India

Tel - 9573911315

Email - arihant@bioneau.com

Website - www.bioneau.com

Description -

As a globally operating corporate, BIONEAU®, an umbrella Conglomerate brand of National-Unispares-Aspire-Enmech-Ecovaan Group of companies, specializes in manufacturing and system integrating complex production & engineering challenges in Pharmaceutical & Biotechnology manufacturing. With a 45+ year rich heritage, we now boast over specialized 14-year long industrial experience in Pharma, Biotech, F&B Segments. We design, manufacture and install reliable Production & Engineering solutions by integrating global technology platforms, to deliver high performing Process Equipments and solutions. Key Portfolio Products § Single Use Integrated Assemblies § Filtration Skids & Systems § Single Use Bioreactors & Mixers, Fluid Management Systems & FDA Spares

Product - Active Pharmaceutical Ingredients, Biotechnology, Clean Room Equipments, Custom manufacturing, Filtration / Separation, Instruments, Laboratory Products and Equipments, Life Sciences, Peptides, Plant / Facility Equipments, Process Automation & Controls, Processing Equipment's, Purification and separation techniques, Validation,

Bionex Process Equipment Pvt. Ltd.

Hall No - Hall4

Booth No - E20

Contact Person - Suman Bhandary

Address - Unit 7 & 8, Tej Kiran Industrial Estate, Near Onida, Navghar, Vasai East

City - Palghar

State - Maharashtra

Zipcode - 401208

Country - India

Tel - 9823234601, 9323087455

Email - sales@bionex.co.in

Website - www.bionex.co.in

Description -

Bionex Process Equipment Pvt Ltd is an engineering company Which Handles Diversified activities in the field of engineering like designing manufacture & suppling of Machineries & process Equipment for Syrup & Ointment & Process Equipment's Syrup & Ointment, Mixers, Blenders, Dryers, Milling, Operation & Filtration, Water Treatment UF+ RO+ DM+ MCDP+PSG Water distribution System With Piping & Process Instrumentation...

Product - Machinery,

Bright India Enterprises

Hall No - Hall4

Booth No - L20

Contact Person - Sanjay Bhide

Address - A/9, Sanjay Building No.5, Mittal Industrial Estate, Andheri Kurla Road, Andheri (E) Andheri (E), Mumbai - 400 059

City - Mumbai

State - Maharashtra

Zipcode - 400059

Country - India

Tel - 9607100088

Email - sb@petalsgroup.com

Website - www.petalsgroup.com/bright

Description -

We are a Pharma Machinery manufacturing company and we manufacture various stand alone products, Syringe pumps and spare and change parts for all types of aseptic filling lines. We want to make better use of the inherent potential of a strong BRIGHT brand. The pharma products we provide are customized according to customer requirements to meet the needs of experts in the field. With the expertise of our employees and the experience of our Managing Director (Joseph Dias) as well as feedback and support from our customers, we can also provide solutions to complete any task.

Product - Filling Equipments, Machinery, Packaging Equipment & Supplies,

Exhibitor Profile

Bry - Air (Asia) Pvt. Ltd.

Hall No - Hall4 **Booth No - M21**

Contact Person - RV Ramana

Address - 21 C Sector 18 Gurugram

City - Gurugram

State - Haryana

Zipcode - 122015

Country - India

Tel - +911244091111

Email - rvramana@pahwa.com

Website - www.bryair.com

Description -

Bry-Air, a Pahwa Group company, is a global leader in dehumidification that offers comprehensive solutions in moisture/humidity control across various industries, including pharmaceuticals, with applications in pharma processing, manufacturing, storage, and packaging. We operate four state-of-the-art manufacturing facilities in India and have fully owned subsidiaries in Malaysia, China, Switzerland, Brazil, and Nigeria, along with an associate plant in the US. With a strong sales and service network, Bry-Air has installations in over 85 countries across various industries, demonstrating the Pahwa Group's commitment to innovation. For more information, visit www.bryair.com.

Product - Dehumidification,

promoters of Carewell Glass & Ampoules Ltd. (who brings in over 28 years of experience in handling and manufacturing of Glass Ampoules and Glass Vials with annual capacity of 1200 million pcs PA).The plant has been set up over 3 acres of land and have a spare 3 acres of land to allow for further expansion. Expansion project for further enhancement of capacity is envisaged.

Product - Primary Packaging for Pharmaceuticals,

CM Pumps and Systems Pvt. Ltd.

Hall No - Hall4 **Booth No - G21**

Contact Person - Zuber Charoliya

Address - Plot no. 191, GIDC Tal: Siddhpur Dist: Patan

City - Patan

State - Gujarat

Zipcode - 384151

Country - India

Tel - 8879002689

Email - info@cmpumps.com

Website - www.cmpumps.com

Description -

Magnetic Drive Sealless Pump

Product - Machinery,

Carewell Pharmapack International Pvt. Ltd.

Hall No - Hall4 **Booth No - A15**

Contact Person - Saaran Bansal

Address - Village Sirsama, Sirsama Road,

City - Kurukshetra

State - Haryana

Zipcode - 136131

Country - India

Tel - 7056444735

Email - info@carewellpharmapack.com

Website - www.carewellpharmapack.com

Description -

We at Carewell Pharmapack has set up an ultra-modern facility designed to meet all regulatory compliance and requirements. The company has been set up by the

Compromec

Hall No - Hall4 **Booth No - G22**

Contact Person - Amresh Singh

Address - G 602, New Golden Nest Phase 14, Mira Rd (E)

City - Thane

State - Maharashtra

Zipcode - 401107

Country - India

Tel - 91-250-2340014

Email - amresh@compromec.com

Website - www.compromec.com

Description -

Complete Machine Solutions for Injectable[Liquid/Lyo & Powder]/Ophthalmic-3 piece/PFS/Cartridge Filling Line/IV products Filling Lines using ISBM Technology

Exhibitor Profile

followed by 100% Inspection of Containers for Particle & Cosmetic defects & Offline/Online Head Space Analysis for Oxygen Sensitive Product for Glass Vials+IV Bags,Low Voltage Bag Inspection for Leak Testing, Process Machines such as Steam Autoclave for different products such as PFS/Machine Parts/ Glass Wares & Washing Machine for Tanks, Processing Vessels & Machine Parts, HEPA Filters for Clean Room & High Temperature HEPA for Sterilization Tunnels, Rotary SS Piston Pumps & Needles with Sterilization Boxes for Pumps & Needles.

Product - Clean Room Equipments, Diagnostics, Filling Equipments, Machinery, Plant / Facility Equipments,

Control Print India

Hall No - Hall4

Booth No - J21

Contact Person - Heena Mistry

Address - 4th Floor, Eden Amsri square Unit no. 408 st. John Road, Near Apollo Hospital

City - Secunderabad

State - Telangana

Zipcode - 500003

Country - India

Tel - 91 22 28599065

Email - heena@controlprint.com

Website - www.controlprint.com

Description -

Control Print Limited (CPL) is India's OWN Coding Equipment Manufacturer, with manufacturing facilities in Nalagarh and Guwahati and a comprehensive support network across India we are India's leading online Coding Solution provider to provide the best engineered and most effective solution across all verticals. Our close to three decades of experience in the Coding & Marking Industry, Control Print has developed a philosophy that consists of partnering with the leading global players technologically.

Product - Coding and Marking,

Crozair Technicea Pvt. Ltd.

Hall No - Hall4

Booth No - B02

Contact Person - Surbhi Varghese K

Address - Unit 09,Ground Floor Madhu Vrinda Industrial Estate, Phase II Sativali Road,Madhu Vrinda Phase II in Dhuri Industrial Estate Complex

City - Mumbai

State - Maharashtra

Zipcode - 401208

Country - India

Tel - 9322033269

Email - surbhi@crozair.com

Website - www.crozair.com

Description -

Real problems need Real answers. We're the perfect match for your strategic critical vacuum needs, because we work hand in glove with our customers across all organizational boundaries. And this close -knit spirit of cooperation has helped us in developing exceptionally deep understanding of our customer's vacuum related needs and their application's requirement. This way we can join together in developing sustainable, step-by-step vacuum solutions. If you'd like to know more good reasons for a long-term partnership with us, go to www.crozair.com

DHV Fitting Pvt. Ltd.

Hall No - Hall4

Booth No - G04

Contact Person - Vikram Shah

Address - 51A, Cutch Castle, No,14B 2nd Floor, JSS Road Opp.Tewari Sweets, Opera House,

City - Mumbai

State - Maharashtra

Zipcode - 400004

Country - India

Tel - 022 66370005/6/8/9

Email - vcs@dhvstainless.com

Website - www.dhvfitting.com

Description -

DHV FITTING PVT LTD manufactures Flanges and Pipe Fittings in Stainless Steel,Carbon Steel & Nickel Alloys. We are an ISO 9001:2015,PED & IBR approved company & have in-house testing facilities for testing like PMI (Positive Material Identification), Microscope, UTM (Universal Testing Machine), Hardness Tester, MPT Testing, Muffle Furnace, IGC Testing and many other facilities. DHV STAINLESS manufactures Stainless Steel, Duplex & Super Duplex Pipe & Tubes. We also manufacture Square & Rectangle pipes. We are an ISO 9001:2015 certified company & have in-house testing facilities like HYDRO TEST & Other testing machines mentioned above.

Exhibitor Profile

Ditap-V Automation Pvt. Ltd.

Hall No - Hall4

Booth No - F16

Contact Person - Akash Kariappa

Address - DitapV House Plot No. 48A, Hill Top Society Talajai Pathar, Dhankawadi

City - Pune

State - Maharashtra

Zipcode - 411043

Country - India

Tel - 8788247837

Email - priyanka.barkade@ditapv.com

Website - www.ditapv.com

Description -

Ditap-V Automation Specialize in complete turnkey EPC Electrical & Automation solution for all Process Plants such as Petrochemical, Chemical, Distillery, Power, Cogeneration, Edible Oil, Dairy, Pharma, Sugar, Food & Beverages, Solvent Extraction, Mining, etc. Ditap-V Executed multiple projects in India, Sri Lanka, Bangladesh, Nepal, France, Switzerland, Germany, USA, Mexico, Nigeria, Thailand, Indonesia, Philippines, Japan etc. as per IEC, CE, UL, & CPRI Standards.

Product - Chemical synthesis / analysis, Instruments, Food & Beverages, Distillery, Pharma, Process Automation & Controls, Processing Equipment's, Solvents,

Drystar India Pvt. Ltd.

Hall No - Hall4

Booth No - E21

Contact Person - Shivangi Mishra

Address - Plot No E-29/9, Karade Budruk, Patalganga Industrial Area Karade khurd, additional Patalganga

City - Panvel

State - Maharashtra

Zipcode - 410220

Country - India

Tel - 8669639876

Email - marketing1@dryrotor.com

Website - www.dryrotor.com

Description -

Drystar India Pvt. Ltd. is a manufacturer, exporter, and supplier of desiccant dehumidifiers with inbuilt AHU, plastic dryers, heat recovery energy-saving equipment, HVAC systems, and clean room projects. . As one of the top producers of highly effective products, we have successfully achieved conditions with a low RH of 5% at a temperature of 22°C in the pharmaceutical industry at reasonable costs. Our products include desiccant dehumidifiers, industrial desiccant dehumidifiers, compact desiccant dehumidifiers, and desiccant dehumidifiers with an AHU unit to attain the lowest RH of 0.5%, a dew point of -40.0, and a temperature of 22°C for lithium battery

Product - Clean Room Equipments, Laboratory Products and Equipments, Machinery, Desiccant Dehumidifier,

E+E Elektronik India Private Limited

Hall No - Hall4

Booth No - J15

Contact Person - Vishakha Shelke

Address - Opp. MTNL office, 801, Lodha Supremus, Andheri East, Sakhi-vihar road,

City - Mumbai

State - Maharashtra

Zipcode - 400072

Country - India

Tel - 9833130869

Email - vishakha.shelke@epluse.com

Website - www.epluse.com

Description -

Development and manufacturing of sensors and transmitters for relative humidity, temperature, dew point, moisture in oil, CO₂, air velocity and mass flow. Development and manufacturing of humidity calibration systems. Accredited calibration laboratory for relative humidity, temperature, dew point, air velocity, mass flow, CO₂ and pressure. Designated laboratory (MNI) maintaining the Austrian national etalons for relative humidity and air flow speed.

Product - Instruments, Electrical and Electronic,

Exhibitor Profile

Ezyprint Technologies

Hall No - Hall4

Booth No - E19

Contact Person - PARUL TOMAR

Address - Plot No-32/33,Shop No: 33, Sector-11,Mermaid-1, CBD Belapur

City - BELAPUR

State - Maharashtra

Zipcode - 400614

Country - India

Tel - 7021680876

Email - ezyprintandtechnologies@gmail.com

Website - www.ezyprinttechnologies.com

Description -

EZYPRINT TECHNOLOGIES

Fermex Solutions LLP.

Hall No - Hall4

Booth No - A07

Contact Person - Poonam Heigher

Address - Plot. no. 149, Sector 82, JLPL Industrial Area, Sahibzada Ajit Singh Nagar,

City - Mohali

State - Punjab

Zipcode - 140308

Country - India

Tel - +917888693232

Email - bd@fermex.in

Website - www.fermex.in

Description -

Established in 2016, Fermex Solutions LLP is a team of three passionate Engineers dedicated to fermentation. We manufacture top-quality Fermenters, customizable for Startups, Universities, Companies, and Research Institutes. With vast experience in fermenter design, process optimization, and innovation, our skilled professionals in Biotechnology, Mechanical Engineering, and Automation ensure the best bioprocessing solutions. Our technologically advanced, user-friendly, and compact Fermenters

cater to specific needs and real-time client feedback. From initial customer contact to successful project commissioning, we manage the entire process, delivering excellence in fermentation equipment and services. Fermex Solutions LLP is your trusted partner for all bioprocessing requirements.

Product - Active Pharmaceutical Ingredients, Antibiotics, Biotechnology, Enzymes, Fine chemicals, Laboratory Products and Equipments, Machinery,

Fillpack Technology

Hall No - Hall4

Booth No - A16

Contact Person - Kashinath Havalgi

Address - Plot No. D 26/6, Anand Nagar, Additional MIDC

City - Ambarnath

State - Maharashtra

Zipcode - 421506

Country - India

Email - fillpackenquiry@gmail.com

Website - www.fillpacktechnology.com

Description -

FILLPACK TECHNOLOGY, an ISO 9001-2015 certified company is strategically headquartered in Ambarnath, Maharashtra, India with two advanced manufacturing units with skilled technocrats & professionals to ensure quality Processing, Filling, packaging machines & dependable after-sales services. We offer you the right machine ally for your Dairy, Food, Beverages, Cosmetic and pharmaceutical processing & Packaging by providing custom-made machine solutions as per your need. We ensure that the containment is secure and of the best quality. Fillpack offers multi-disciplinary Engineering design and description Services exploiting intelligent and state of art technology applications.

Product - Machinery, Packaging Equipment & Supplies, Processing Equipment's,

Exhibitor Profile

Filtromix Equipments LLP

Hall No - Hall4

Booth No - A18

Contact Person - Jayesh Shah

Address - 3, Acme Industrial Park, I B Patel Road Near Fern Hotel, Goregaon-(East)

City - Mumbai

State - Maharashtra

Zipcode - 400063

Country - India

Tel - 9821354747

Email - filtromix@hotmail.com

Website - www.filtromix.com

Description -

Multi Process Equipment For Api Excipients. Plough Shear Mixer/Dryer/Vacuum Dryer/Pressure Reactor

Product - Active Pharmaceutical Ingredients, Excipients and Drug formulation, Fine chemicals, Machinery, Processing Equipment's,

Fit-Wel Industries LLP

Hall No - Hall4

Booth No - A22

Contact Person - Tejpal Sanghvi

Address - Unit No-10, Tulsi Bldg Ground floor, 166-180 Khetwadi back road

City - Mumbai

State - Maharashtra

Zipcode - 400004

Country - India

Tel - +91-22-23829256

Email - tejpal@fitwelindia.com

Website - www.fitwelindia.com

Description -

MANUFACTURER & SUPPLIER OF Pipes, Pipe Fittings, Flanges, Long Radius Bends, Dairy & Bio Pharmaceutical Fittings In Stainless Steel, Carbon Steel, Alloy Steel, High Nickel Alloys, Duplex & Super Duplex Since 1987

Foxx Life Sciences

Hall No - Hall4

Booth No - H19

Contact Person - Eknath Kulkarni

Address - H no:2-34/B, SY no:65 Rajabollaram Village Medchal

City - Hyderabad

State - Telangana

Zipcode - 501401

Country - India

Tel - + 914023792022

Email - eknath.kulkarni@foxxlifesciences.com

Website - www.foxxlifesciences.in

Description -

Foxx Life Sciences is a privately held world leader in custom single-use systems (SUS) including tubing, bag, bottle, flask, and carboy assemblies, filtration, fluid management, laboratory safety products, plastic labware, tubing, gaskets, hoses, stainless steel and glassware for the research, biotech, and pharmaceutical industries. With a focus on quality (ISO 13485 since 2010) and our certified ISO Class 7 cleanrooms, Foxx is the perfect partner for your next single use custom assembly. Foxx holds a wide variety product patents that allows us to offer highly-competitive products for cost-sensitive projects in extremely short timeline.

Product - Laboratory Products and Equipments, Life Sciences,

GAMP Services Pvt. Ltd.

Hall No - Hall4

Booth No - M08

Contact Person - Gaurav Shah

Address - GAMP services pvt ltd 303, sahyog Elina, VIP Road, Karelibaug

City - Vadodara

State - Gujarat

Zipcode - 390018

Country - India

Tel - 9925839723

Email - gauravshah@gampservices.com

Website - www.gampservices.com

Description -

GAMP Group of companies has focus on the Validation for the life science industry. GAMP services have expertise for multi angle smoke study, thermal

Exhibitor Profile

validation, advance computer system validation as per GAMP 5 protocol and CQV (commissioning Qualification and Validation) and utility and HVAC validation services GAMP services pvt ltd provides quality instruments related to clean room monitoring and validation, thermal validation, air flow visualization set up, HEPA filter testing instruments and Process analytical Tools (PAT) for real time process monitoring GXP solutions manufacture the quality process machinery like autoclave, manufacturing tank, SIP CIP skid with automation.

Product - Clean Room Equipments, Contract Services, Instruments, Process Automation & Controls, QA & QC, Testing and Measurement, Validation,

Gandhi Automations Pvt. Ltd.

Hall No - Hall 4 **Booth No - C02**

Contact Person - Akshay Shah

Address - Chawda Commercial Centre Link Road Malad West

City - Mumbai

State - Maharashtra

Zipcode - 400064

Country - India

Tel - +91 22 66720200 / 300

Email - marketing@geapl.co.in

Website - www.geapl.co.in

Description - Since 1996, Gandhi Automations Pvt Ltd has led in manufacturing, exporting, and installing Entrance Automation Systems and Loading Bay Equipment. Specializing in custom products, we emphasize safety, reliability, and energy efficiency. Collaborating with European partners, our engineering technology ensures quality. Our team uses advanced software and machinery for exceptional solutions. With a 500,000 sq ft facility in Bhiwandi, India, we ensure superior quality in every product.

Product - Automation and Robotics, Health and Safety Products, Plant / Facility Equipments, Process Automation & Controls,

Getinge Medical India Pvt. Ltd.

Hall No - Hall4

Booth No - L19

Contact Person - Pooja Goradia

Address - 203 and 204, B-Wing, Fulcrum, Sahar Road, Andheri (East)

City - Mumbai

State - Maharashtra

Zipcode - 400099

Country - India

Tel - 7400094748

Email - pooja.goradia@getinge.com

Website - www.getinge.com

Description -

As a partner in pharmaceutical production, Getinge's portfolio of biopharmaceutical resources meets our customers' unique challenges and strict compliance requirements while achieving high performance, maximum productivity and streamlined processes. We produce GMP washers, sterilizers, closure processing systems, isolators, sterile transfer systems and bioreactors systems to meet each facility's specific needs. The integrity of scientific data produced in modern biomedical research and laboratory facilities is of paramount importance to humanity. Safe and contamination-free research facilities and laboratories are therefore essential. We produce laboratory and biomedical washers, sterilizers, automated handling systems and bioreactors to ensure contamination-free experiments and tests.

Product - Laboratory Products and Equipments, Life Sciences, Machinery, Processing Equipment's,

Exhibitor Profile

Go Ezylift Tech Pvt. Ltd.

Hall No - Hall4

Booth No - C16

Contact Person - Ashish Mehta

Address - Unit No. 9-10, Janta Industrial Estate, K.T. Park 1, Gourai Pada

City - Vasai E

State - Maharashtra

Zipcode - 401208

Country - India

Tel - 8956134359

Email - sales@ezylift.in

Website - www.goezylift.in

Description -

We have pleasure in introducing ourselves as leading manufacturers of material handling equipment's of Ezylift brands for the following range: EOT/HOT/JIB Cranes & Spark-proof cranes: Up to 35 MT capacities. Wire rope electric hoists & flameproof hoists: Up to 20 MT capacities. Goods-lifts standard & flameproof type: Up to 7.5 MT capacities. Electric chain hoists: Up to 2 MT capacities. Chain Pulley Blocks, standard & non-sparking type: Up to 20 MT capacities. Hydraulic Scissor Lifts: Up to 7 MT capacities. Hydraulic Stackers: Up to 2.5 MT capacities. The Basic Parameters of the machines are: 1) Streamlined & aesthetically pleasing

Product - Machinery,

GSS Engg Private Limited

Hall No - Hall4

Booth No - C08

Contact Person - Prajakta Satam

Address - Madhuvrinda Dhuri Industrial Complex-1, Phase 1, Unit No-14 Sartivali Road, Waliv Phata, Vasai (East)

City - Palghar

State - Maharashtra

Zipcode - 401208

Country - India

Tel - 9967771358

Email - pes@gssengg.com

Website - www.gssengg.com

Description -

GSS HIGH PRESSURE HOMOGENIZER

Product - Processing Equipment's,

Harikrushna Technopride Engg.

Hall No - Hall4

Booth No - H16

Contact Person - Trushil Trivedi

Address - C/2A/8, Phase I, GIDC Estate, Vatva, Opp SBI Bank

City - Ahmedabad

State - Gujarat

Zipcode - 382445

Country - India

Tel - 079 - 40033010

Email - trushil@harikrushnatechnopride.com

Website - www.harikrushnatechnopride.com

Description -

Our company M/s. Harikrushna Technopride Engg. was established in year 1996 under the proprietorship of Mrs. Niharika M Trivedi, We had started a small manufacturing unit and our initial product was Sticker Labeling machine, thereafter as a result of our continuous hard-work and R & D we were able to develop Pre Filled Syringe Filling & Stoppering machine. We are one of the leading manufacturers & exporters of various types of machineries for Pharmaceutical, Beverages, Dairy, Food, Cosmetic & Allied Industries since 1996 & are specialized in Injectable, Prefilled Syringe Filling & Stoppering (Closing) machines.

Product - Machinery,

Hemochrom Ultrapure

Hall No - Hall4

Booth No - M16

Contact Person - Ajay Kunder

Address - 5, Kinny Corner Bldg., Before HDFC Bank, I.C. Colony, Borivali - W

City - Mumbai

State - Maharashtra

Zipcode - 400103

Country - India

Tel - 9967689955

Email - ajay@hemochrom.com

Website - www.hemochrom.com

Description -

Hemochrom manufactures HPLC columns. Our wide range can easily replace most regular brands but are priced 30% lower. HPLC columns are available in C18,

**KINDLY
VISIT
OUR
STALL**

WE ARE

EXHIBITING

PHARMALYTICA

2024

Reynold India Pvt. Ltd. is the largest manufacturer of Process Chillers. Our Product range includes the advanced Screw Chillers, versatile Scroll Chillers, Brine Chillers, Oil Chillers, Gas liquefaction Chillers, Batching Chillers, Cascade Chillers

STALL NO.

HITEX, HYDERABAD / 30 MAY - 01 JUNE 2024

L-15

Hs No 2-9-57/37/13, GSR Enclave, Risala Bazaar,
Secunderabad-500010, Telangana, India

Exhibitor Profile

C8, silica, cyno, phenyl, amino, Chiral etc in all sizes upto 1.7micron. Having manufacturing facility in India, we assure faster delivery times for odd dimension columns. Ultra Pure does impurity isolation from APIs, Formulations, bulk drugs, intermediates, natural products etc. which are even as low as 0.1% including chiral isolation. After isolation, we characterize the impurities to assign them a structure. We do analytical method development, validation, stability studies for API, Finished goods, plant extraction, lyophilization

Product - Analytical Equipments, Chemical synthesis / analysis, Chiral intermediates, Filtration / Separation, Instruments, Laboratory Products and Equipments, Purification and separation techniques, QA & QC, Testing and Measurement, Validation,

HLE Glascoat Ltd.

Hall No - Hall4

Booth No - K02

Contact Person - Manish Khokrale

Address - Plot no. A3,A6,A7, Block no 140B Paiki Plot no. 4&5, Maroli Udyognagar

City - Navsari

State - Gujarat

Zipcode - 396436

Country - India

Tel - 2637-270150

Email - manish.khokrale@hleglascoat.com

Website - <https://www.hleglascoat.com/>

Description -

ANF, ANFD, RVPD, RCVD, RDDC, Orbicular Dryer, Heli Cone Dryer, Autoclave, Hydrogenator, Column, Heat Exchanger, GLR, GL tanks

Product - Batching Systems / Equipments, Filtration / Separation, Machinery, Processing Equipment's,

Hygro Tech Engineers

Hall No - Hall 4

Booth No - H15

Contact Person - Nagaraj V

Address - 61 & 62, Kachohalli Gate, Behind Rajarajeshwari Kalyana Mantapa Magadi Main Rd

City - Bangalore

State - Karnataka

Zipcode - 560091

Country - India

Tel - +91 80 2977 6001/02

Email - nagarajv@hygrotechindia.com

Website - www.hygrotechindia.com

Description -

Hygro Tech Engineers an ISO 9001:2015 Indigenous manufacturing company with 2 decades of experience in providing humidity solutions, arrived to treat moisture problems in the applications like Food industries, Seed industries, Pharma, Defense, Eng Aerospace etc... Hygro Tech is an application company involved in air control and stimulation to sustain the desired environment with their unique air treatment products like Dehumidification Systems, Product Drying Chamber, Low RH Dry Rooms, Low Temperature Drying systems etc. Hygro Tech is global supplier with their HO, works & R&D based in Bangalore and having a sales and after sales services across south Asian countries.

Product - Filtration / Separation, Machinery, Process Automation & Controls, Purification and separation techniques,

Inceptbio Pvt. Ltd.

Hall No - Hall4

Booth No - J22

Contact Person - Anand R

Address - #24, 22nd Main Marenahalli, JP Nagar, 2nd Phase

City - Bangalore

State - Karnataka

Zipcode - 560078

Country - India

Tel - +916366942391

Email - anand@inceptbio.com

Website - www.inceptbio.com

Description -

Solving pharma Challenges

Product - Automation and Robotics, Biotechnology, Clean Room Equipments, Consulting services, Contract Services, Instruments, Laboratory Products and Equipments, Life Sciences, Process Automation & Controls, QA & QC, Regulatory affairs, Validation,

Exhibitor Profile

Indo Rama Engineers

Hall No - Hall4 **Booth No - K19**

Contact Person - Ankur Aggarwal

Address - Plot No. 9, Village Rampur Jattan Sirmour

City - Kala Amb

State - Himachal Pradesh

Zipcode - 173030

Country - India

Tel - 9215466664

Email - indoramapharma@gmail.com

Website - www.indoramapharma.in

Description -

Indo Rama is the fastest-growing company that offers reliable medications that promote healthy lifestyles. Since our Company's inception, our business procedures have been governed by quality medication, fairness, and compliance with all regulatory requirements. With two distinct Units—Indo Rama Unit-1 (Indo Rama Engineers) for softgels and the Indo Rama Unit-2(Indorama Healthcare Pvt. Ltd.) for Tablets, Capsules, Oral Liquids(Syrups), and Oral Liquid (Sachets)—it is feasible to meet the vast majority of client expectations within the specified time frame.

Product - Active Pharmaceutical Ingredients, Capsules / encapsulation, Contract Services, Custom manufacturing, Exipients and Drug formulation, Peptides, Phospholipids, Plant / Facility Equipments, Tablet disintegrants,

Infionic

Hall No - Hall 4 **Booth No - H17**

Contact Person - Subramanyam SP

Address - 4th Flr, Sanali Spazio Madhupur

City - Hyderabad

State - Telengana

Zipcode - 500081

Country - India

Tel - 9963907930

Email - subbu@infionic.com

Website - www.infionic.com

Description -

Infionic is an enterprise software company that focuses on Process Manufacturing industries. Infionic has CFR Part 11 Compliant software in the space of ERP, Document Management System, Training Management and Quality Management System. We also provide solutions in the space of Project Management, CRM and HRM.

Product - Computer software,

Informa Test 011

Hall No - 4 **Booth No - Test001**

Contact Person - Yash Kamble

Address - andheri

City - Mumbai

State - Maharashtra

Zipcode - 400069

Country - India

Tel - 0192919190

Email - yash.kamble@informa.com

Description -

Hi It is a test

Product - Amino acids, Microencapsulation,

Innovative Engineers Hvac Pvt. Ltd.

Hall No - Hall4 **Booth No - K20**

Contact Person - VIVEK SINHA

Address - A-701, Synergy Tower, Near Vodafone House, Corporate Road, Prahladnagar

City - Ahmedabad

State - Gujarat

Zipcode - 380015

Country - India

Tel - 9974921569

Email - viveks@innovativeengineer.net

Website - www.innovativeengineer.net

Description -

Hvac Managemnet Company.

Exhibitor Profile

Integrated Cleanroom Technology Pvt. Ltd.

Hall No - Hall4

Booth No - L02

Contact Person - Pavan Kumar

Address - 3rd Floor, Ratna Arcade, Kompally Medchal Highway

City - Hyderabad

State - Telangana

Zipcode - 500014

Country - India

Tel - 91-40-27165311

Email - pavankumar@icleantech.com

Website - www.icleantech.com

Description -

Integrated Cleanroom Technologies Pvt Ltd (ICLEAN) a group Company of Takasago Thermal Engineering Co. Ltd., (TTE), Japan is the leading Cleanroom Manufacturer from India, providing total cleanroom solution on turnkey basis. ICLEAN is a one stop solution provider for design, manufacture, installation, commissioning & validation of complete modular cleanrooms along with seamlessly integrated HVAC system. Product list include Cleanroom Partitions, Cleanroom Accessories, Lab Furniture, Fume hoods, Air Handling Units including HVAC, BMS, and Electrical etc. For more details please refer our website www.icleantech.com

Product - Clean Room Equipments, Cleanroom Turnkey Solutions,

Ipsons Pharma Equipments Pvt. Ltd.

Hall No - Hall4

Booth No - H12

Contact Person - Kirti Patil

Address - Bhanji Udyog Nagar Hotel Ajit Place Lane Penkarpada, Mira Rd. East

City - Thane

State - Maharashtra

Zipcode - 401107

Country - India

Tel - +91 7507054804

Email - kirti@ipsonspharma.com

Website - www.ipsonspharma.com

Description -

IPSONS PHARMA, A pioneering force in the realm of pharmaceutical machinery manufacturing. With an unwavering commitment to innovation, precision, and excellence, we stand as a distinguished leader in providing cutting-edge solutions to the pharmaceutical industry. Our product range includes Auto Coater, HSMG, FBS, Vibro Sifter, Multi Mill, Rotary Sifter, Cone Mill, V Blender, Bin Blender, Octagonal Blender, Double Cone Blender, Roll Compactor, Oscillating Granulator, Product Transfer System, Tablet Inspection Machine, Metal Detector-De Duster combo, Colloid Mill, Lifting & Positioning Device, Cone Extruder with Spheronizer, Tablet Compression Machine, Capsule Filling Machine, catering to the varied needs of our esteemed clients.

Product - Active Pharmaceutical Ingredients, Exipients and Drug formulation, Filling Equipments, Laboratory Products and Equipments, Machinery, Processing Equipment's,

Jain Steel Tube Co.

Hall No - Hall4

Booth No - A19

Contact Person - Jenil Shah

Address - 1, Chheda Bhavan, Ground Floor, Surat Street, Masjid Bunder East

City - Mumbai

State - Maharashtra

Zipcode - 400009

Country - India

Tel - +91-9930766808

Email - jainsteeltube@hotmail.com

Website - www.jaisteeltube.com

Description -

Jain Steel Tube Co, your premier destination for high-quality pneumatic patented technology, manufactured by Exen Corp, Exen Air Knocker, Suction Feeder, and Vibration Technology Products, manufactured in Japan We also cater for structural steel, pipes, fittings, Valves, Hoses, Filters, Gaskets and allied product requirements as per your customization

Product - Automation and Robotics, Clean Room Equipments, Custom manufacturing, E-business, Filling Equipments, Filtration / Separation, Instruments, Machinery, Exen Air Knocker, Suction Feeder, and Vibration Technology Products, manufactured in Japan as well, Plant / Facility Equipments, Process Automation & Controls, Processing Equipment's,

Exhibitor Profile

Jainex Electricals & Engineering Co.

Hall No - Hall4

Booth No - K17

Contact Person - Rajkumar Dugar

Address - 5.2--210 to 212, Shop no 1 & 2 Y.Y Yadi Reddy Complex, Hyder Basti Ranigunj, Secunderabad

City - Hyderabad

State - Telangana

Zipcode - 500003

Country - India

Tel - 04040051747, 04029305353, 9849128762

Email - jainexelec@gmail.com

Description -

Jainex Electricals Is A Supplier Of Top Quality Flp Lights, Fans, Switchgears, Panels, Glands, Wires & Cables, Cleanroom Lighting & Switchgears, Safety Equipments, Led Lighting, Spares. We Are Approved Vendors To All Major Pharma, Chemical, Cement, Contractors, Oil & Gas Companies Across India. We Have Ready Stocks Of All Items. We Also Undertake Customised Items. We Are Authorised Distributors Of: Simex Flameproof Industries, Flametech Switchgears, Haria Metals, Sigma Industries, Crompton, Kei Industries

Product - Active Pharmaceutical Ingredients, Alkaloids, Amino acids, Antibiotics, Biochemicals, Biotechnology, Capsules / encapsulation, Chemical synthesis / analysis, Chiral intermediates, Clean Room Equipments, Fine chemicals, Instruments, Intermediates, Laboratory Products and Equipments, Life Sciences, Machinery, Medicinal plants, Microencapsulation, Peptides, Plant / Facility Equipments, Process Automation & Controls, Processing Equipment's, QA & QC, Regulatory affairs, Testing and Measurement,

Jetspray Innovations Pvt. Ltd.

Hall No - Hall4

Booth No - M22

Contact Person - Pandian Charles

Address - Plot No. 55, Sector 1A, CIDCO Service Industrial Area, Airoli (W)

City - Navi Mumbai

State - Maharashtra

Zipcode - 400708

Country - India

Tel - 022-41205328/32405751

Email - charles@jetsprayinnovations.com

Website - www.jetspray.in

Description -

JETSPRAY INNOVATIONS PVT LTD is an ISO 9001:2015 Cert. Organization & a Leading Brand in the process industry. We are constantly working to provide meaningful innovations & solutions for our client's requirements. For the last 8 years, our focus has been to develop meaningful products that make life simple & easy for our clients with regard to process equipment cleaning & sampling systems.

Product - Active Pharmaceutical Ingredients, Alkaloids, Amino acids, Antibiotics, Antibodies, Antimicrobial preservatives, Antioxidants, Batching Systems/Equipments, Biochemicals, Biotechnology, Capsules / encapsulation, Chemical synthesis / analysis, Chiral intermediates, Clean Room Equipments, Cytokines, Emulsifying / solubilising agents, Enzymes, Exipients and Drug formulation, Filling Equipments, Filtration / Separation, Fine chemicals, Flavours and perfumes, Health and Safety Products, Herbal teas, Hormones & synthetic substances, Immunochemistry, Intermediates, Laboratory Products and Equipments, Life Sciences, Machinery, Medicinal plants, Microencapsulation, Ointments bases, Packaging Equipment & Supplies, Peptides, Phospholipids, Plant / animal extracts, Plant / Facility Equipments, Process Automation & Controls, Processing Equipment's, Prostaglandins, Purification and separation techniques, Sera and Vaccines, Solvents, Suspending / viscosity increasing agents, Sweetening agents, Synthetic organic chemistry, Tablet disintegrants, Tablet filler-binders, Tablet lubricants, Tableting / Capsule fillers, Validation, Wetting / solubilizing agents,

Jubilant Piping Solutions Pvt. Ltd.

Hall No - Hall4

Booth No - C15

Contact Person - Udit Chauhan

Address - Survey no 773/P1, Rajpur Indrad Road, Village Irana, taluka Kadi, Dist. Mehsana

City - Mehsana

State - Gujarat

Zipcode - 382715

Country - India

Tel - 7227096004

Email - marketing@jpipings.com

Website - www.Jpipings.com

Description - Manufacturers of Butt weld / Forged Fittings and Flanges

Exhibitor Profile

Kinam Engineering Industries Pvt. Ltd.

Address: Plot No. 112, 1st Floor (Part-01), Sion Garage Building, Above Croma, Near Sion Circle, Sion (East), Mumbai - 400022

Factory: Plot No. M-4, MIDC, Pale Phase-III, Industrial Area, Additional Ambernath, Village – Pale, Taluka Ambernath, District–Thane 421506, India.

Email -sales@kinam.in

Website: <https://kinam.in>

Tel - : +91-(0)22-461-77687/88/89

Description -

Kinam Engineering Industries, a family-owned business founded in 1981, has earned its reputation of “The Heat Exchanger Specialist” through the three core values: Top-quality Products, Happy Customers, and Outstanding Service. Fostered over by years of experience in both manufacturing and thermal designing of Heat Exchangers, Kinam has become one of the leading manufacturers of Shell & Tube Heat Exchangers (STHE), Corrugated Tube Heat Exchangers (CTHE), Spiral Heat Exchangers (SPHE), Plate Heat Exchangers (PHE) & Box Type Heat Exchangers.

Kinam has marked its presence across the globe by catering to its clientele in various countries, with industries ranging from Chemical, Petrochemical, Fertilizers, Refineries, Pharmaceutical, Biotech, Oil, Paper, Steel, Cosmetics, and Textile Industries.

With extensive research and proven results, Kinam has developed the next-generation heat exchanger “KICC”. These exchangers are most efficient when it comes to condensing applications.

Thanks to innovative designs, advanced technology, excellent manufacturing facilities, and skilled workmanship, Kinam has successfully delivered over 14,000+ systems, gaining the trust of 500+ clients on over 6 continents.

Kinam Engineering Industries has joined forces with HLE Glascoat Limited, a top process equipment manufacturer, marking a new chapter of growth and innovation. HLE Glascoat Limited is now the largest stakeholder in Kinam; this partnership will enable us to pivot to the next phase of our growth journey.

Kinam, with its remarkable achievements, continues to grow & be the leader in the heat transfer industry committed to excellence and customer satisfaction.

Products: KICC Corrugated Tube Heat Exchanger, Shell and Tube Heat Exchanger, K-SPEX Spiral Heat Exchanger, K-PEX Plate Heat Exchanger, KIC-BOX Heat Exchanger, Exchangers in Exotic Materials.

Klimapharm Technologies Pvt. Ltd.

Hall No - Hall4

Booth No - H03

Contact Person - Naumaan Momin

Address - B-408, Lodha Supremus-II, Wagle Industrial Estate, Road No-22,Thane(W)

City - Mumbai

State - Maharashtra

Zipcode - 400604

Country - India

Tel - +91 22 4006 7887

Email - naumaan@klimapharm.com

Website - <http://www.klimapharm.com>

Description -

Klimapharm, a global leader in turnkey cleanroom solutions, offers expertise across pharmaceuticals, healthcare, biotech, FMCG, and more. Our services meet the highest standards, including USFDA, UKMHRA, ASME, EUGMP, ISPE, ISO, TGA, and FDA compliance. Comprehensive solutions cover HVAC, cleanroom panels, stainless steel equipment, electrical work, and BMS, tailored to each project. Operating from a 4600-square-metre facility, we produce 1000 square metres of panels and 75 doors daily, ensuring unmatched efficiency. Recognised as the Best Emerging Cleanroom Projects & Solutions provider at the India Pharma Awards 2023, we extend our global reach to 15 countries, guaranteeing seamless execution worldwide.

Product - Biotechnology, Clean Room Equipments, Consulting services, Custom manufacturing, Filtration / Separation, Laboratory Products and Equipments, Machinery, Testing and Measurement, Validation,

Exhibitor Profile

KTT Pharmatech

Hall No - Hall4

Booth No - I03

Contact Person - Sameer Kocharekar

**Address - Plot no. 17, Manish Industrial Estate no 4
Opp Tania Commercial Complex Navghar road, Vasai
East**

City - Palghar

State - Maharashtra

Zipcode - 401208

Country - India

Tel - +9193200 01571

Email - sameer@kttpharmatech.com

Website - www.kttpharmatech.com

Description - We, at KTT Pharmatech, strive to achieve the highest possible level of efficiency and effectiveness in the management and operation of our company in order to deliver our best. In doing so, we leave no stone unturned when it comes to upgrading and updating ourselves with the latest technology. Our state-of-the-art manufacturing facilities, well-trained engineering team and dedicated production crew enable us to offer competitive price without compromising on quality. With specialized technological access and services, we are capable enough to surpass every sphere of our customer's demands. We are at the forefront of research and development in the areas

Product - Clean Room Equipments, Clinical Trials, Consulting services, Instruments, Machinery, Plant / Facility Equipments, Processing Equipment's, Tableting / Capsule fillers,

Labguard India Pvt. Ltd.

Hall No - Hall 4

Booth No - J02

Contact Person - Smita Dalvi

**Address - 104,105,Odesa Boutique Offices Road No,
9 Wagle Ind Est.**

City - Thane

State - Maharashtra

Zipcode - 400604

Country - India

Tel - 7506042435

Email - marketing@labguard.in

Website - www.labguard.in

Description -

LabGuard India Pvt Ltd, a renowned Indian manufacturer of premium Fume Hoods and Laboratory Furniture, has a rich three-decade history of innovation and unwavering quality commitment. With a strong presence in India and exports to 30 countries, we hold prestigious global certifications like ASHRAE110:2016, EN14175, SEFA 1,8, & 10. We have thrice earned the India Design Mark Award for pioneering fume hood designs. We proudly introduce Eka, India's first high-performance fume hood, backed by our professional team and our in-house fume hood performance test lab. We remain a trusted laboratory furniture supplier to universities, research institutions, and QC/QA labs worldwide.

Product - Laboratory Products and Equipments,

Lennox Clean Air Technologies

Hall No - Hall4

Booth No - H08

Contact Person - Mohammad Irfan

**Address - Survey No. 172, Plot No. 155/B, IDA
Bollaram, Jinnaram Mandal**

City - Sangareddy

State - Telangana

Zipcode - 502325

Country - India

Tel - 9908448484

Email - info@lennoxcleanair.com

Website - www.lennoxcleanair.com

Description - Lennox Clean Air Technologies is a customized clean room solutions provider. Since its foundation in 2014, Lennox has sophisticated a comprehensive understanding and expertise of executing Clean Room Solutions, Turnkey HVAC and clean room projects. Lennox has to its credit many successful project executions extent across an array of Industrial, Commercial, Healthcare, Pharmaceutical and Biotechnology. Our success lies in our core values and uncompromising guarantee of quality in last 4 years. It is because of these core values – we are a chosen vendor for all our clients, and rated as the paramount company to consult for future developments.

Product - Clean Room Equipments,

Exhibitor Profile

Lisaline Lifescience Technologies Pvt Ltd .

Hall No - Hall4

Booth No - I20

Contact Person - Sagar Brahme

Address - 401-D, Wifi Park Plot no. B-3, Road no. 3 Wagle Ind Est.

City - Thane

State - Maharashtra

Zipcode - 400604

Country - India

Tel - 02225834982

Email - sagar.brahme@lisalineasia.com

Website - www.lisalineasia.com

Description - Lisaline Lifescience Technologies Pvt. Ltd. An established company with 25 years of providing Cold Chain Monitoring and Maintaining solutions in India, Middle East and South Asia. • In 1998, Lisaline started their journey of bringing Cold chain Innovations with introduction of Vaccine Vial Monitors (VVMs) to Indian vaccine industry. • Our clients include pharmaceuticals, Vaccine Manufacturers, Biologicals, CROs, Blood Banks, etc. • ISO 9001:2015 organization • WHO approved testing lab • Colour Changing Chemical temperature indicators • Wireless datalogging solution • Shipment Monitoring Single and Multiple Use PDF Loggers • Active & Passive Cooling Solutions Solutions for QR code

Product - Clinical Trials, Contract Research, Diagnostics, Life Sciences, Plant / Facility Equipments, Process Automation & Controls,

Lotus Technicals Pvt. Ltd.

Hall No - Hall4

Booth No - H20

Contact Person - Ravindra Sonkusare

Address - 1601&1602, Oriana Business Park, Road No. 22, Wagle Estate, Thane (West)

City - Thane

State - Maharashtra

Zipcode - 400604

Country - India

Tel - 22-20810798/20810598

Email - huzaiifa.shaikh@lotustechnicals.com

Website - www.lotustechnicals.com

Description - We are a pharmaceutical engineering company specialized in providing complete Turnkey solutions (Clean Room Panels, Hvac, Equipments & Validation, Electricals, Piping, Utilities etc) to pharmaceutical companies. Right from Concept to Commissioning, Validation, Start up till handover, we partner our clients at every phase of their project cycle. We design & engineer project for formulations like OSD, Liquids, Sachets, Sterile Injectables – SVP, LVP, Lyophilized vials, Vaccines & others.

Product - Life Sciences, Machinery, Plant / Facility Equipments, Process Automation & Controls, Processing Equipment's, Purification and separation techniques,

Lucky Deep Cleanroom Pvt Ltd

Hall No - Hall4

Booth No - L14

Contact Person - Bhushan Pawar

Address - Gat no. 15413, Chavan Mala Vilholi

City - Nashik

State - Maharashtra

Zipcode - 422010

Country - India

Tel - 98500 58410

Email - sales@luckydeep.com

Website - www.luckydeep.com

Description -

With over 22 years of experience in HVAC Cleanroom cross contamination Control, Lucky Deep is a group of firms with Indian roots. Proficiency in Pharma manufacturing concepts, detailed design, planning, supply, erection, commissioning, and validation. Modular Cleanroom panels, doors and accessories are our speciality as high quality product manufacturers. Lucky Deep Cleanroom Pvt. Ltd. is a part of Lucky Deep Air Conditioning. As one of the top businesses providing HVAC Cleanroom Solutions, Lucky Deep Air Conditioning was founded in 2007. Offering exceptional and top-notch HVAC Cleanroom solutions at affordable pricing, it is a knowledge-based and technology-based company.

Product - Clean Room Equipments,

Exhibitor Profile

Mahashakti Pharmamach

Hall No - Hall4

Booth No - G19

Contact Person - Bipin Panchal

Address - 64 & 69, Gangotri Industrial Estate, Opp. Panchratna Ind. Estate B/S. Ramol Over Bridge, Ramol Cross, GIDC, Vatva

City - Ahmedabad

State - Gujarat

Zipcode - 382445

Country - India

Tel - 9426767717

Email - sales.mahashakti@gmail.com

Description -

Manufacturers of spares and change parts for Pharma Machinery viz. Washing Machine; Injectable Filling and Stoppering Machine, Capping Machine and Sticker Labelling Machine as well as Vibrator Bowl and Schute of Stoppers; Inner Plugs; Caps; Pumps and Actuators etc. Engineering Plastic, Poomps parts; farbrication etc.

Product - Spares for Pharmaceutical Washing, Filling, Stoppering, Capping and Labelling machines, Packaging Equipment & Supplies,

Masseprazise

Hall No - Hall 4

Booth No - L11

Contact Person - Harsh Mehta

Address - Tirumala Hans Industrial Park, Plot no 18, Near Super Corridor Tigaria Badshah

City - Indore

State - Madhya Pradesh

Zipcode - 452001

Country - India

Tel - 6264915873

Email - suppoert@masseprazise.com

Website - http://masseprazise.com

Description -

Masseprazise- The Best & Biggest Manufacturer of Calibration Weights & Fractional Weight Box (E1 E2 F1 F2 M1 M2) as per the International Standard OIML R111.

Product - Laboratory Products and Equipments,

Mechmaark Filtech India Pvt. Ltd.

Hall No - Hall4

Booth No - K15

Contact Person - Pooja Gupta

Address - Khewat no- 265, Min 1226 Khata no 279 Min, villa No- 13/7/2, 8/2, 13/1, 14/1, Village Tandaheri,

City - Bahadurgarh

State - Himachal Pradesh

Zipcode - 124507

Country - India

Tel - 9910189277

Email - pooja.gupta@mechmaark.in

Website - www.mechmaark.in

Description -

Mechmaark was established in 2009 having its headquarters at Delhi. Our manufacturing plant is located in Bahadurgarh Haryana and Hyderabad Telangana. Mechmaark is the largest number one Indian Filter manufacturing company. Products manufactured by us are of International standards with high performance rating and quality benchmarked for all International Industry standards. We market our products at all over India & we have six (4) offices all across the country at Delhi, Mumbai, Ahmedabad & Hyderabad. Other than India we also export our product to nine (8) countries. Within a very short span of time our products have been accepted by various reputed OEM /AHU

Product - FILTER MANUFACTURERS,

Exhibitor Profile

Meknetics Innovations Pvt. Ltd.

Hall No - Hall4 **Booth No - B16**

Contact Person - Shraddha Sinha

Address - 4th floor, 11/1551, Sunpaul Dizera Blueberry Complex, Expressway, Near Infopark Kakkanad, Rajagiri Valley

City - Ernakulam

State - Kerala

Zipcode - 682039

Country - India

Tel - +91 99207 50639

Email - shraddha@meknetics.com

Website - www.meknetics.com

Description -

Since its establishment, Meknetics has strived to provide exemplary engineering consultancy services for F&B, Pharmaceutical, Nutraceutical, Biotech, Dairy, Rubber & Tyre and other process industries. Over the years, we have grown in leaps and bounds. Today, we are a company with a team of young, talented and passionate professionals with a reputation in the engineering and process industry. We firmly believe in establishing lasting client relationships while providing comprehensive packages of top-quality product and service of exceptional value. We provide our clients with a wide range of engineering turnkey solutions, including design, engineering, manufacturing, installation, commissioning, and validation of systems.

Product - Machinery,

Mmp Industries Ltd.

Hall No - Hall4 **Booth No - H22**

Contact Person - Ankur Bhandari

Address - B-24, Hingna MIDC Area, Umred

City - Nagpur

State - Maharashtra

Zipcode - 440016

Country - India

Tel - 9925226984

Email - ankurb@mmpil.com

Website - www.mmpil.com

Description -

Manufacturing Bare Foil, Blister Foil & Pharma Foil.

Product - Packaging Equipment & Supplies,

Moreschi Asia Doors P. Ltd.

Hall No - Hall4

Booth No - D12

Contact Person - Sivakrishna Kothuru

Address - Plot no 6, Shed No.2, IDA Bollaram, Near Miyapur, Shed No. 2 IDA Bollaram, NearMiyapur,

City - Hyderabad

State - Telangana

Zipcode - 502325

Country - India

Tel - 7032820763

Email - sivakothuru@moreschiasia.com

Website - www.moreschisrl.com

Description -

Moreschi Asia Doors is a wholly-owned subsidiary of Moreschi Srl, a leading provider of Industrial Doors. We specialize in the Design, Manufacturing & Installation of various types of doors: Folding Doors, Sliding Doors, Speed Roll-Up Doors, Insulated & Single-Skin Rolling Shutters, Steel Doors, Dock Levellers & Shelters, Sectional Doors with modern technology. Moreschi Doors Located in Hyderabad, operates with modern technology to cater to the needs of the Indian and Asian markets having a state-of-the-Art Manufacturing Facility. Expertise in: Folding Doors, Sliding Doors, Speed Roll-Up Doors, Insulated & Single-Skin Rolling Shutters, Steel Doors, Dock Levellers & Shelters and Sectional Doors.

Product - Industrial Doors(Folding & Sliding Doors, Speed Roll Up Doors, Rolling Shutters,

Exhibitor Profile

Mrb Forge & Fitting LLP.

Hall No - Hall4

Booth No - D11

Contact Person - Manish Bhandari

Address - Plot No. 55, 56 & 57, Kamla Amrut Industrial Park Opp. Torrent Pharma, Ahmedabad - Mehsana Highway Vill. Indrad, Tal. Kadi, Dist. Mehsana - 382715

City - MEHSANA

State - GUJARAT

Zipcode - 382715

Country - India

Tel - 9979366644

Email - info@mrbmetals.com

Website - www.mrbmetals.com

Description -

MRB Forge & Fittings LLP. is a trusted manufacturer specializing in a comprehensive range of pipe fittings and flanges. Our Expertise: • **Stainless Steel:** We provide a wide selection of stainless steel pipe fittings and flanges, known for their excellent corrosion resistance and durability. • **Carbon Steel:** Our cost-effective carbon steel options are ideal for applications requiring strength and affordability. • **Alloy Steel:** For projects demanding exceptional strength and high-temperature performance. • **Exotic Materials:** We offer exotic materials like Hastelloy, Inconel, and Monel, renowned for their exceptional resistance to harsh chemicals and extreme temperatures. We prioritize quality with industry certifications.

Product - Plant / Facility Equipments,

Munters India Humidity Control Ltd.

Hall No - Hall 4

Booth No - A12

Contact Person - Narayana Patil

Address - Gat No. 26/1, 27, (P), Shed No.2, Sanghar Warehousing, Property No. 1697, Village Lonikand, Pune 412216

City - Pune

State - Maharashtra

Zipcode - 412216

Country - India

Tel - +91 20 66818900

Email - narayan.patil@munters.com

Website - www.mumters.com

Description -

Munters is a global leader in climate solutions for mission-critical processes. We offer innovative, efficient, and sustainable solutions for customers in industries where controlling temperature and humidity is mission-critical.

Product - Capsules / encapsulation, Clean Room Equipments, Custom manufacturing, Health and Safety Products, Laboratory Products and Equipments, Life Sciences, Machinery, Providing rooms /process with low humidity requirement., Packaging Equipment & Supplies, Plant / Facility Equipments, Processing Equipment's,

Nanoprecise Sci Corp

Hall No - Hall4

Booth No - L17

Contact Person - Indu Moola

Address - IndiQube- Edge Service Centre Khatha No. 571/630/6/4 Sy No.6/4), Ambalipura Village, Outer Ring Road, Varthur, Hobli,

City - Bengaluru

State - Karnataka

Zipcode - 560103

Country - India

Tel - 080 4881 1211

Email - imoola@nanoprecise.com

Website - <https://nanoprecise.io/>

Description -

Nanoprecise Sci Corp. pioneers AI-driven energy centered predictive maintenance, revolutionizing industrial operations worldwide. Our advanced technology integrates 6-in-1 sensors with AI algorithms for precise real-time machinery health predictions. This empowers industries globally to slash unplanned downtime and energy usage. Serving a broad spectrum of sectors like oil & gas energy, mining, and infrastructure, Nanoprecise leads the charge in efficiency enhancement.

Product - Laboratory Products and Equipments, Plant / Facility Equipments, Process Automation & Controls, Processing Equipment's,



CREATING STRONGER BONDS

Global Presence In **95+** Countries

10,000+ Customers Worldwide

100,000+ Pharmaceutical &
Non-pharmaceutical
Research Molecules In Catalogue

Why Choose Pharmaffiliates?

Synthetics

Analytics

Reference Materials

HPLC Columns

Pharmaffiliates Analytics and Synthetics (P) Ltd., founded in Year 2001, is a leading & integrated Contract Research & Development Organization (CRDO) service provider of "Custom Synthesis R&D" with its global presence & operating in compliance with US-FDA, EU-GMP, MHRA and ICH guidelines.

ISO 17034 Accredited
US-FDA Audited & Accepted



www.pharmaffiliates.com

Exhibitor Profile

Network Inc

Hall No - Hall4

Booth No - I18

Contact Person - Kamlesh Gala

Address - B007 Antop Hill Warehousing Complex
Near Barkat Ali Naka Vidyalkar Marg Wadala E
Mumbai-400037

City - MUMBAI

State - Maharashtra

Zipcode - 400037

Country - India

Tel - 022-24193501

Email - kamlesh@network-india.com

Website - www.network-india.com

Description -

Authorized distributor for EBM PAPST Cooling Fans & Blowers

Product - Authorized Distributor,

New Bio Scientific Company

Hall No - Hall4

Booth No - L16

Contact Person - Dinesh Kumar M

Address - Plot no. 94, Road no. 8 Kadkola Industrial
Area Kadkola

City - Mysore

State - Karnataka

Zipcode - 571311

Country - India

Tel - 08212952703

Email - dinesh@nbsgroups.in

Website - www.nbsgroups.in

Description -

Manufacturing of Bio Process Equipments

Product - Biotechnology, Laboratory Products and Equipments,

Nicomac Taikisha Cleanrooms Pvt. Ltd.

Hall No - Hall4

Booth No - E02

Contact Person - Narendra Reddy A

Address - Plot no 116, I.D.A Bollaram, Near Miyapur

City - Hyderabad

State - Telangana

Zipcode - 502325

Country - India

Tel - 8978388004

Email - narendra@nicomactaikisha.com

Website - www.taikisha-cleanrooms.com

Description -

NICOMAC TAIKISHA CLEAN ROOM SYSTEM is most advanced for various industries including pharmaceuticals. We offer the highest quality products such as cleanroom panels, doors, windows clean room equipment's manufactured according to international QA and safety standards using European and Japanese technology, and our skilled installation staff provide a clean room with a high quality and attractive appearance. In addition, by partnership with Taikisha Ltd. (Japanese multinational corporation) since 2020, we are capable of offering TURNKEY project management support and services including Design, Construction, Project support, installation and unique devices, system on a world-wide basis.

Product - Clean Room Equipments, Custom manufacturing, Modular cleanroom panels,

Novasix Technologies Private Limited

Hall No - Hall 4

Booth No - I04

Contact Person - MAHESH GADHAVE

Address - Plot No 203, Anjali Soc, Flat No.102, Moshi, Khed,

City - PUNE

State - MAHARASHTRA

Zipcode - 411062

Country - India

Tel - 9987472055

Email - mahesh@novasixt.Com

Website - www.Novasixt.Com

Description -

Novasix Technologies Pvt Ltd Is An Entity That Takes Care Of Process Design, Procurement. On Start-To-Finish(Turnkey) Engineering Solutions For Pharmaceutical, Sterile Formulations, Bio-Pharmaceutical, Vaccines And Mdi/Biotech And Healthcare Companies All Over The World.

Product - Antibiotics, Biotechnology, Capsules / encapsulation,

Exhibitor Profile

Omega Scientific Instruments Pvt. Ltd.

Hall No - Hall4

Booth No - I15

Contact Person - Narayana Murthy

Address - # 20, 3rd Main, Rukmini Apartments Road, New Bel Road, RMV 2nd Stage P.O

City - Bangalore

State - Karnataka

Zipcode - 560094

Country - India

Tel - 080 23416613

Email - info@omegascientific.com

Website - www.omegascientific.com

Description -

We are all about Quality... To be precise. Manufacturers of High Quality Stainless Steel Filtration Products & Accessories like Mixing Vessels & Systems, Storage Vessel Systems, Fermentation Systems, Jacketed Vessels, Purified Water Systems, Water for Injection, Generation, Storage Systems, Multi Round Housings, other Pharma / Biotech Downstream Process Equipments. Aseptic Processing, Injectable Manufacturing customers prefer Omega's products due to High amount of Technical Expertise in 21 CFR, Automation & Instrumentation are few of our strengths.

Product - Automation and Robotics, Biotechnology, Filling Equipments, Filtration / Separation, Plant / Facility Equipments, Process Automation & Controls, Processing Equipment's, Purification and separation techniques,

Origin Corporate Services Pvt. Ltd.

Hall No - Hall4

Booth No - B12

Contact Person - Ujjwal D Gadhvi

Address - Dalamal Towers, 9th Floor, 906 Nariman Point, Free Press Journal Marg

City - MUMBAI

State - Near Mantralaya

Zipcode - 400021

Country - India

Tel - 9152004949

Email - crm@origincorp.com

Website - www.origincorp.com

Description -

Origin is here to supply dehumidifiers in India. Since 1998, we've been cooperating with the best brands in the industry, so whether you're interested in humidity control appliances from Germany, Italy or Singapore, we have them all. With us, you can be sure to get a unit of uncompromising quality to dehumidify any place. Origin's experts are always ready to help you choose the right dehumidifier, considering all your requirements and needs. Whether you're about to get a dehumidifier for a commercial or residential building, we carry many dehumidifiers for sale to choose from.

Product - Active Pharmaceutical Ingredients, Alkaloids, Amino acids, Analytical Equipments, Antibiotics, Antibodies, Antimicrobial preservatives, Antioxidants, Automation and Robotics, Batching Systems / Equipments, Biocatalysts, Biochemicals, Bioinformatics, Biotechnology, Capsules / encapsulation, Chemical synthesis / analysis, Chiral intermediates, Clean Room Equipments, Clinical Trials, Coating agents, Colour and dispersions, Computer software, Consulting services, Contract Research, Contract Services, Custom manufacturing, Cytokines, Data services, Diagnostics, Drug delivery systems, E-business, Emulsifying / solubilising agents, Enzymes, Excipients and Drug formulation, Filling Equipments, Filtration / Separation, Fine chemicals, Flavours and perfumes, Glidants, Health and Safety Products, Herbal teas, Hormones & synthetic substances, Immunochemistry, Instruments, Intermediates, Laboratory Products and Equipments, Life Sciences, Machinery, Medicinal plants, Microencapsulation, Ointments bases, Dehumidifiers, Packaging Equipment & Supplies, Peptides, Phospholipids, Plant / animal extracts, Plant / Facility Equipments, Process Automation & Controls, Processing Equipment's, Prostaglandins, Publisher, Purification and separation techniques, QA & QC, Regulatory affairs, RFID, Sera and Vaccines, Solvents, Stiffening agents, Stiffening bases, Suppository bases, Suspending / viscosity increasing agents, Sweetening agents, Synthetic organic chemistry, Tablet disintegrants, Tablet filler-binders, Tablet lubricants, Tableting / Capsule fillers, Testing and Measurement, Tissue culture medias, Validation, Wetting / solubilizing agents,

Exhibitor Profile

Pharma Spares Pvt. Ltd.

Hall No - Hall4

Booth No - M12

Contact Person - Shweta Jadhav

Address - Factory Address: Plot No. 7, Survey no. 241, Hissa No. 1, Village Gokhivare, Chinchpada, Vasai (E), Ram Mandir Road Goregaon (West)

City - Hyderabad

State - Telangana

Zipcode - 401 20

Country - India

Tel - 91-22-67061023

Email - shweta@pharmaspares.com

Website - www.pharmaspares.com

Description -

We, at Pharma Spares Pvt Ltd, have been providing Sieving Solutions to Pharmaceutical industry for more than a decade. We are leading manufacturer and suppliers of sieves and screens for sifting, filtration, granulation, milling, drying, extrusion and other operations. We are the inventors of the 'LEAD FREE SIEVE' Design. This sieve meets the criteria set by the USFDA & has been approved for use in Pharma Companies which follow the USFDA standards. Quality of our products meets FDA cGMP standards for safe processing of pharmaceutical powders. We are offering all validation & calibration documents as per the ISO, USFDA, &

Product - Active Pharmaceutical Ingredients, Filtration / Separation, Health and Safety Products, Machinery,

Pharmaffiliates Analytics & Synthetics (P.) Ltd.

Hall No - Hall 4

Booth No - B21

Contact Person - Amit Shrivastava

Address - Plot no 225 Industrial Area, Phase 2 Panchkula (Haryana) Industrial Area 2, Panchkula,

City - Panchkula

State - Haryana

Zipcode - 134109

Country - India

Tel - +91-172-5066494-45

Email - bda@pharmaffiliates.com

Website - www.pharmaffiliates.com

Description -

Pharmaffiliates Analytics & Synthetics Pvt. Ltd. is a Contract Research & Development Organisation (CRDO) audited and accepted by USFDA & accredited with ISO 17034 . We have rich experience of more than 21 years in serving customers across the globe comprising major Pharmaceutical companies, API manufacturers, Bulk drug suppliers, clinical CROs and other allied industries . Our main areas of expertise includes Custom synthesis, Analytical Research & Development, Contract Research & Manufacturing Services (CRAMS), Stability Studies .

Product - Biotechnology, Chemical synthesis / analysis, Contract Research, Contract Services, Custom manufacturing, Fine chemicals, Peptides, Synthetic organic chemistry, Validation,

Pharmcrux

Hall No - Hall 4

Booth No - G25

Contact Person - P. Venkatapathi Raju

Address - Flat no. 301, Vaghdevi Residency, Deepthi Sree Nagar, Miryapur

City - Hyderabad

State - Telengana

Zipcode - 500049

Country - India

Tel - 9000624456

Email - engineering@pharmcrux.com

Website - www.pharmcrux.com

Description -

Provides various services to the pharmaceutical industry which includes cGMP consultancy, third-party audits, US Agent services, DMF Filing across the globe and computer system validations. Developing software solutions to various work flows in pharmaceutical industries like 1. Material Management. 2. Learning Management System (LMS) 3. Quality Management System (QMS) 4. Document Management System (DMS) 5. eLog 6. Stability 7. eLab 8. Customer Relationship Management (CRM).

Product - Active Pharmaceutical Ingredients, Clean Room Equipments, Data services, E-business, Instruments, cGMP Consultancy, QA & QC, Regulatory affairs,

Exhibitor Profile

Polmon Instruments Pvt. Ltd.

Hall No - Hall 4 **Booth No - F15**
Contact Person - Tajammul Hussain
Address - Polmon House, Nizampet Road, Kakutpally,
City - Hyderabad
State - Telengana
Zipcode - 500085
Country - India
Tel - 00914023057308
Email - MKTG@polmon.com
Website - www.polmon.com

Description -

Polmon is an ISO 9001 2015 certified company serving the Life Sciences and Chemical Industries for more than 30 years. Polmon offers Instruments, Process Automation Solutions and Heat Transfer Systems. Please visit www.polmon.com for more information on Products and Services offered by Polmon. You may also write to us at info@polmon.com

Product - Active Pharmaceutical Ingredients, Automation and Robotics, Clean Room Equipments, Fine chemicals, Instruments, Life Sciences, Machinery, Process Automation & Controls,

Pontos Labcare Private Limited

Hall No - Hall4 **Booth No - C21**
Contact Person - Kishansinh Rathod
Address - Plot No-29, Vibrant Mega Industrial Park, Zak to Kadadara Road, Vehlal,
City - Ahmedabad
State - Gujarat
Zipcode - 382330
Country - India
Tel - 7043077747
Email - kishan.rathod@pontosindia.com
Website - www.pontosindia.com

Description -

Pontos Labcare Private Limited Is Renowned Manufacturer Of Laboratory Furniture And Fume Hoods With An Accomplished Team. We Have Successfully Executed Over 3500 Projects In This Domain.visit Our Exhibition Booth To Discover Our Exceptional Expertise In Laboratory Solution .

Product - Laboratory Products and Equipments,

Pr Pharma Engineers Pvt. Ltd.

Hall No - Hall4 **Booth No - B08**
Contact Person - K Pulla Reddy
Address - Plot No. 113/A/1, Lane No. 8 Phase II IDA Cherlapally
City - Hyderabad
State - Telangana
Zipcode - 500051
Country - India
Tel - 9908202658
Email - pr@pharmaengineers.com
Website - www.pharmaengineers.in

Description -

deals with HVAC & Clean room equipment's, we are specialized in AHU & Customised Equipments
Product - Clean Room Equipments, Contract Services, Custom manufacturing,

Prachi International Lights (supernova)

Hall No - Hall 4 **Booth No - J16**
Contact Person - KASHISH SHAH
Address - Plot No-4, S No. 35/2, 9/1, 97/1, W. E .Highway Village Sativali,Vasai (E),
City - PALGHAR
State - Maharashtra
Zipcode - 401208
Country - India
Tel - 9029656535
Email - oasisluminaires@gmail.com

Description -

Supply of cleanroom fittings

Product - Custom manufacturing,

Exhibitor Profile

Prasad Meditech

Hall No - Hall4

Booth No - D19

Contact Person - ASHISH DARADE

Address - PAP-W96, Varale Chakan M.I.D.C. Phase II
Tal. Khed

City - Pune

State - Maharashtra

Zipcode - 410501

Country - India

Tel - 9960981043

Email - ashish.darade@prasadmeditech.com

Website - www.prasadmeditech.com

Description -

Prasad Meditech is India's leading manufacturer and biggest exporter of Eurohead Caps used in packing of Infusion Solution Bottles and Bags. All the IV Bottle Caps manufactured in Prasad Meditech are USDMF approved. At present the company supplies its products to 17 countries worldwide.

Product - Packaging Equipment & Supplies,

Prime Care Technology Pvt. Ltd.

Hall No - Hall4

Booth No - E15

Contact Person - Urvi Barot

Address - Plot No. 7/8, Akshar Industrial Park, Opp. Zydus Cadila, Sarkhej-Bavla Road, Moraiya Road, Changodar

City - Ahmedabad

State - Gujarat

Zipcode - 382213

Country - India

Tel - 9081555464

Email - urvi.barot@t3am.in

Website - www.t3am.in

Description -

leading manufacturer of state-of-the-art Bio process equipment designed to revolutionize your bioprocessing capabilities.

Product - Biotechnology, Life Sciences, Machinery, Process Automation & Controls, Processing Equipment's,

Propack Technologies Pvt. Ltd.

Hall No - Hall4

Booth No - H02

Contact Person - Chintan Shah

Address - 317, Hill View Industrial Estate Off L.B.S Marg Ghatkopar (West)

City - Mumbai

State - Maharashtra

Zipcode - 400086

Country - India

Tel - 91-22-25002610

Email - mkt2@propacktechnologies.com

Website - www.propacktechnologies.com

Description -

Propack Technologies is a Pharmaceutical Machine Manufacturer that has been supplying Process equipment & systems for Pharmaceutical, Bioprocessing & Cosmetic industries worldwide for over 20 years. We are a Pharma equipment manufacturing company that offers end-to-end processing solutions from conceptualization, design, engineering, fabrication & commissioning to our customers. Propack Technologies has an exceptional team, modern manufacturing facilities and highest quality standards that make us a reliable name in Pharmaceutical Machinery Manufacturing

Product - Biotechnology, Custom manufacturing, Machinery, Plant / Facility Equipments, Processing Equipment's,

Exhibitor Profile

Rafeeq Filtration Systems (3r Filters)

Hall No - Hall 4 **Booth No - A01**

Contact Person - Muhammed Iliyaz Siddiqui

Address - 7-2-221/16, Ashok colony, Santhnagar,

City - Hyderabad

State - Telengana

Zipcode - 500018

Country - India

Tel - 7032799545

Email - contact@rafeeqfilters.com

Website - www.rafeeqfilters.com

Description -

With over 25 years of industry experience, Rafeeq Filtration Systems (3r FILTERS) has earned its reputation as manufacturing a complete line of Hydraulic Filters, Air filters, Sifter sieves, screens, Industrial filters, Pipeline Basket Strainers, Extruder Screens, Filter Disc, Dust Collector Filters, Filter bags, Cartridge Filters, Filter Housings for the global industries such as Pharmaceuticals, Polymers, Chemical, Food & Beverages, Refineries, Cement, Paper & Textile.

Product - Clean Room Equipments, Contract Services, Custom manufacturing, Filtration / Separation, Instruments, FILTERS, SIEVES, SCREENS, Processing Equipment's,

Rahul Ferromet & Engineering Pvt. Ltd.

Hall No - Hall4 **Booth No - M02**

Contact Person - Rupjyoti Haloi

Address - 609, Sanket Heights, Nr. Akshar Chowk,

City - Vadodara

State - Gujarat

Zipcode - 390020

Country - India

Tel - 022 2652981100

Email - sreddy@rensatubes.com

Website - www.rensatubes.com

Description -

Rensa Tubes has been a stalwart manufacturing stainless steel pipes and tubes for over 18 years. Our cutting-edge 20,000 sq. M facility in Jhagadia, Gujarat, boasts an integrated Tube and fittings production line. Innovations include robotic polishing, ASME BPE & 3A -certified products, and sustainable practices. Rensa Tubes excels in precision, setting industry benchmarks with surface finishes (SF4 & SF1). With a robust production capacity, we aspire to be your partner in success. Explore more at www.rensatubes.com and anticipate excellence beyond compare.

Product - Biotechnology, Clean Room Equipments, Flavours and perfumes, Herbal teas, Laboratory Products and Equipments, Life Sciences, Machinery, Packaging Equipment & Supplies, Plant / Facility Equipments, Processing Equipment's,

Raindrop Aqua Solutions

Hall No - Hall4 **Booth No - L13**

Contact Person - M Poornanandam

Address - Plot No 2 & 3, Flat No- G1, P.R Nilayam Behind NRE college, Bandari Layout,

City - Nizampet

State - Telangana

Zipcode - 500090

Country - India

Tel - 9949545554

Email - poorna.madala@raindropaqua.com

Description -

Electronic water descaling system

Product - Water Treatment,

Exhibitor Profile

Ram Equipment

Hall No - Hall4

Booth No - A11

Contact Person - Dhruvak Patel

Address - B/1/125, Ravipark C.H. Soc. Ltd., Nr. H Colony, Madhuvrund, Ghatlodia,

City - Ahmedabad

State - Gujarat

Zipcode - 380061

Country - India

Tel - +91 9998931989

Email - dhruvak@ramequipment.in

Website - www.ramequipment.in

Description -

RAM EQUIPMENT is an authorized distributor of leading German companies RIEGER (Rieger GmbH + Co. KG) & AWH (Armaturenwerk Hötenleben GmbH) in India. We provide wide range of solutions in Valve Technology, Mixer Technology, Cleaning Technology and Product Recovery Technology to various Industries like: Pharma, Biopharma, Food & Beverages, Dairy, Chemical, Brewery and Cosmetics mainly where clean technology is required. We offer ASEPTIC and HYGIENIC products which are designed to work better with your process equipment by providing maximum process safety, long service life, reduce maintenance costs, decrease downtime and improve productivity.

Product - Filling Equipments, Machinery, Processing Equipment's,

Reynold India Pvt. Ltd.

Hall No - Hall4

Booth No - L15

Contact Person - Vishal Soma

Address - Building C-38 & 39 Sector 2

City - Noida

State - Uttar Pradesh

Zipcode - 201301

Country - India

Tel - 9971396904

Email - industrialsouth2@reynoldindia.com

Website - www.reynoldindia.com

Description -

Reynold India Pvt. Ltd. is the largest manufacturer of Process Chillers in India, having exports to over 60 countries around the world, including EU & US. Our Product range includes the advanced Screw Chillers, versatile Scroll Chillers, rugged Reciprocating Chillers as well as Customized Chillers, precisely designed and made as per the peculiar process cooling applications, some of them being Brine Chillers, Industrial Chiller, Oil Chillers, Gas liquefaction Chillers, Batching Chillers, Air Chiller, Air Cooled Chiller, Cascade Chillers, Water Cooled Chiller, Hazardous area Chillers etc. We are accredited through various prominent international organisations for the management as well as engineering processes

Product - Batching Systems / Equipments, Laboratory Products and Equipments, Life Sciences, Chiller Manufacturers, Processing Equipment's,

S. G. Pharmatec

Hall No - Hall4

Booth No - B20

Contact Person - Satywan Gaikwad

Address - Asian Industrial Hub, Unit No. 02, Plot No.3, Survey No.80 National Highway-8, Shirsad, Virar

City - Virar

State - Maharashtra

Zipcode - 401208

Country - India

Tel - 9930173651,9869068695,9833883916

Email - sales@sgpharmatec.com

Website - www.sgpharmatec.com

Description -

Manufacturers of various Pharma Machines namely OSD equipment, Liquid Mfg. Plant, Liquid Filling Line, Dry powder Filling Line, Auto Coaters, Manufacturing, Mixing, Storage Vessels, Labeling Machines, Infrared Dryers Chambers, Scizzor Lifter, Ointment Mfg. Plant, Lifters etc. S G Pharmatec is in the field for more than 10 years and many more machines are supplied to multinational/ multimillion pharma companies. Well reputed for quality of products and after sales service.

Product - Machinery, Packaging Equipment & Supplies, Processing Equipment's,

Exhibitor Profile

Saakvee Technologies India Pvt. Ltd.

Hall No - Hall4

Booth No - A08

Contact Person - Veeresh Chavan

Address - Office no. 614, Niharika Mirage Kpora rd, Sector 10 Kharghar

City - Navi Mumbai

State - Maharashtra

Zipcode - 410210

Country - India

Tel - 022-20875050

Email - md@saakvee.com

Website - www.saakvee.com

Description -

Trunkey HVAC and clean room projects.

Product - Clean Room Equipments, Laboratory Products and Equipments, Machinery, Validation,

Sagar Air Pvt. Ltd.

Hall No - Hall4

Booth No - I21

Contact Person - Vishveshwar T V

Address - Plot No 96-97,IDA Uppal

City - Hyderabad

State - Telengana

Zipcode - 500039

Country - India

Tel - 7093333682

Email - vishveshwar@sagarair.com

Website - www.sagarair.com

Description -

Manufacturers of Desiccant Dehumidifiers-Standalone,ACDs, Hygienic Air Handling Units,Energy Recovery Units, All kinds of Cooling and Heating Coils

Product - Machinery, Processing Equipment's,

Sangama INC

Hall No - Hall4

Booth No - K22

Contact Person - Shiva Kumar P K

Address - #77, 4th Cross Shriniketh Layout Singapura

City - Bengaluru

State - Karnataka

Zipcode - 560097

Country - India

Tel - 9740066460

Email - shivakumar.pk@sangamainc.com

Website - www.sangamainc.com

Description -

We are dedicated enterprises committed to delivering effective engineering solutions tailored to the requirements of the Pharma, Biopharma, and Food and Beverage Industries. By integrating the technical demands of the pharmaceutical sector with customer preferences, we streamline manufacturing processes and ensure optimal solutions. Our range of offerings includes sales and service for Replacement Diaphragms, Elastomers, Hoses, Lobe Pumps, Magnetic NRVs, Stainless Steel valves, devices for plants and tanks, Tubes and fittings, and single-use products. Additionally, we specialize in the customization of equipment to meet specific customer needs. We assure you Best Quality, Best service, Best Price and Faster Delivery

Product - Filling Equipments, Plant / Facility Equipments, Processing Equipment's,

Schneider Electric India Pvt. Ltd.

Hall No - Hall 4

Booth No - D02

Contact Person - Bishwajit Sircar

Address - Survey # 215, Bldg # 2-24/1, Gagillapur Village Madak Road

City - Hyderabad

State - Telangana

Zipcode - 508248

Country - India

Tel - 7428098413

Email - bishwajit.sircar@se.com

Description -

Schneider Electric SE is a French multinational company that specializes in digital automation and energy management. It addresses homes, buildings, data centers, infrastructure and industries, by combining energy technologies,real-time automation, software, and services.

Exhibitor Profile

Scientific Devices (Bombay) Pvt. Ltd.

Hall No - Hall 4

Booth No - C12

Contact Person - Wasaib Khan

Address - Scientific Centre, S. No 65, Hissa No.7, Bye Pass Junction, Kausa, Mumbra

City - Thane

State - Maharashtra

Zipcode - 400612

Country - India

Tel - 7715814717

Email - sales@scientificdevices.org

Website - www.scientificdevices.org

Description -

We are AN ISO 9001:2015, 14001 : 2004, CE Certified, DNV Type Approved, NABLA Accredited, ATEX and IBR Certified Company engaged in Designing, Manufacturing and Supply of Flow, Level, Temperature, Pressure Measurement And Control Instruments, Sight Glasses, Breather Valve, Flame Arrestor And Pipe Line Strainers since past 30 years used for Chemical Process, Petrochemicals, Power generation, Oil & Gas, Pharmaceutical, Ship building, steel, water and waste water treatment plants and Cement Industries etc.

Product - Instruments, Testing and Measurement,

Scientific Research Instruments Company Private Limited

Hall No - Hall 4

Booth No - I02

Contact Person - Nishanth Kamath

Address - 42-43, 1st Cross Road, Raghavendra Residential layout off Gubbalala main road, Gubbalala

City - Bengaluru

State - Karnataka

Zipcode - 560061

Country - India

Tel - 080 47572577

Email - nishanth@srico-labworld.com

Website - www.srico-labworld.com

Description -

Scientific Research Instruments Company Private Limited, [SRICO], is a professionally managed Laboratory Equipment Company established to

deliver the best solutions available from internationally reputed manufacturers in the field of Research and Development, Quality Control & Process for Industries and Institutions. SRICO's primary focus is to address the laboratory equipment-related needs of companies, institutions and universities (from both government and private sectors) which are active in the fields of Chemical, Petrochemical, Pharmaceuticals, Biotechnology & Life Sciences, Agricultural & Veterinary Sciences & Food and Environmental Sciences. "Our mission is to deliver total Customer satisfaction"

Product - Biotechnology, Chemical synthesis / analysis, Clean Room Equipments, Instruments, Laboratory Products and Equipments, Life Sciences, Processing Equipment's,

Shah Brothers

Hall No - Hall 4

Booth No - K14

Contact Person - Priyanka Bapat

Address - Bldg No E 9 Unit no 25&26, Bhumi World Industrial estate Mumbai Nashik Highway, Pimplas village

City - Bhiwandi

State - Maharashtra

Zipcode - 421311

Country - India

Tel - 02522-672447,672445,672448,672450,672451

Email - priyanka@shahbros.com

Website - www.shahbros.com

Description -

With a legacy spanning 75 illustrious years, "Shah Brothers" is an esteemed industry leader, propelled by the visionary leadership of Mr. Jayant Shah. Operating under the renowned brand "Inteviz," our company is a distinguished localized manufacturer of RTU single-use assemblies, validated to provide a SAL of 10⁻⁶. We proudly offer a diverse portfolio of global offerings catering to the pharmaceutical & biopharmaceutical industry. Within our comprehensive range, we specialize in tubings, connectors, fittings, hoses, pumps, and other fluid handling components, we epitomize excellence, reliability, and unwavering dedication to providing cutting-edge solutions that empower industries.

Product - Biotechnology, Clean Room Equipments, Custom manufacturing, Filtration / Separation, Instruments, Laboratory Products and Equipments, Purification and separation techniques,

Exhibitor Profile

Shrirang Automation and Controls

Hall No - Hall4

Booth No - F20

Contact Person - Pavan Kumar Pyla

Address - Plot No 733, Road No 85, Gidc Sachin,

City - Surat

State - Gujarat

Zipcode - 394230

Country - India

Tel - 8799554670

Email - pavan@sanc.in

Website - www.sanc.in

Description -

SANC is a Trusted supplier of high-quality sensors and control panels for various industries, offering efficient and cost-effective solutions to customer. SANC's mission is to provide quality products and service to our customers at reasonable cost with an emphasis on safety, proper application and efficiency, as well as to effectively represent the interests and good reputation of our principals being a Channel Partner.

Product - Instruments, Process Automation & Controls,

Sitriv Optronics Corporation

Hall No - Hall4

Booth No - L22

Contact Person - Margaret Dsouza

Address - 326, T V Industrial Estate, Behind Glaxo, Dr Annie Besant Road, Worli Sea Face,

City - Mumbai

State - Maharashtra

Zipcode - 400030

Country - India

Tel - 9820721146

Email - sales1@trivtech.net

Website - www.sitriv.in

Description -

SITRIV brings to India Quality Products for Pharma, Biotech Semi-Conductor Applications. NEUMO-ASME-BPE Tubes, Tees, Reducers Clamp Ferrules, Clamps, Gaskets, Aseptic Tube Connections, End Caps, Aseptic Heat Exchangers, Insulation Systems, Special Alloys Tube-Fittings, Special Connections, Valves EGMO - Premium Quality Pioneer Manufacturer of ASME BPE Fittings - Elbow, Tees, Reducers, Clamps, Ferrules,

Solid End/Weld Caps, Gaskets, Hose Adapters. AWH - Magnetic Mixers, Pipes / Fittings, Valves, Sight Glasses, Pigging Systems, Tank Cleaning Equipment. RIEGER - High Quality Hygienic-Aseptic Valves - Single Seat, Mix Proof, Double Seal, Filling, Sampling, Flow Control, Overflow, Safety, Block, Seat, etc.

Product - Tube & fittings for Pharma, Semiconductor, food & beverages Industries,

Skytech Systems (I) Pvt. Ltd.

Hall No - Hall4

Booth No - K21

Contact Person - Vijetha Shetty

Address - 403-404, Siddheshwar Arcade, Opp Suraj Water Park, Ghodbunder Road,

City - Thane

State - Maharashtra

Zipcode - 400615

Country - India

Tel - 022 - 4153 33342

Email - marketing@skytechindia.com

Website - www.skytechindia.com

Description -

Established in 1993 Skytech Systems (I) Pvt Ltd stands as a pioneering force in the field of analytical instrument distributor in India. Our mission is clear: to empower scientific progress by making available the latest technological Analytical instruments from around the globe to Pharmaceutical, Refinery, laboratories, research institutes, universities etc throughout India. We deliver not just products, but comprehensive solutions that empower researchers, analysts, innovators etc to push the boundaries of knowledge and finding. Our primary focus is on delivering unparalleled service and support to a diverse range of clients.

Product - Chemical synthesis / analysis, Contract Services, Instruments, QA & QC, Testing and Measurement, Validation,

Dwyer

DWYEROMEGA

Evikon



YOUR TRUSTED PARTNER FOR HIGH QUALITY SENSORS

WE SPECIALIZE IN

- PRESSURE
- TEMPERATURE
- FLOW AND LEVEL



DIFFERENTIAL PRESSURE SWITCH
For filter application



AIR VELOCITY TRANSMITTER
Measuring air velocity in duct



HANITM CLAMP-ON TEMPERATURE SENSOR
Non-invasive & non-contact measurement



MAGNEHELIC GAUGE
Indicates differential pressure



DIGITAL MAGNEHELIC
For clean room and machines



DIFFERENTIAL PRESSURE TRANSMITTER
Duct static pressure measurement & filter status



PHOTOHELIC GAUGE
Combines differential pressure gage with low/high set-points

FOR MORE DETAILS : +91 8652 220 362 | info@sanc.in

www.sanc.in

Exhibitor Profile

SMS Instruments Pvt. Ltd.

Hall No - Hall 4

Booth No - B22

Contact Person - Prasanth G Nair

Address - Block III IDA Plot No C 1, Uppal Main Road

City - Hyderabad

State - Telangana

Zipcode - 500039

Country - India

Tel - 7899763355

Email - PNair@surfacemeasurementsystems.com

Website - www.surfacemeasurementssystem

Description -

At Surface Measurement Systems LLC (SMS), we aim to expand the frontiers of particle, materials, and surface science. SMS is well-known for their expertise in developing unique characterisation solutions for solid state materials, from manufacturing state-of-the-art instrumentation to offering tailored characterisation solutions. SMS Holdings now operates all across the world, with 5 subsidiaries spread between its instrumentation branches and contract laboratories. Whether it's our unrivalled series of sorption analyzer instruments, or the in-depth contract analysis services on offer, SMS is a globally-renowned organization that remains synonymous with innovative engineering and scientific excellence, unmatched in the field of sorption science.

Product - Active Pharmaceutical Ingredients, Analytical Equipments, Chemical synthesis / analysis, Contract Research, Contract Services, Excipients and Drug formulation, Fine chemicals, Flavours and perfumes, Laboratory Products and Equipments, Peptides,

Description -

Manufactures of Speciality Packaging Suppliers for Pharmaceutical, Medical Devices and Health care Industries since 2012.

Product - Packaging Equipment & Supplies,

Spectrum Filtration Pvt. Ltd.

Hall No - Hall4

Booth No - L12

Contact Person - Minal Patki

Address - Plot No. - J - 535, J Block Pimpri Chinchwad Industrial Area

City - Pune

State - Maharashtra

Zipcode - 411026

Country - India

Tel - 9836911009

Email - minal.patki@spectraco.in

Website - www.spectraco.in

Description -

Spectrum Filtration having more than 26 Yrs with Five manufacturing plant all over India, we have been consistently providing specialty Air Filtration products and services that meet or exceed our customer's expectation of quality and performance - on time, every time. A leading and engineering brand engaged into manufacturing of Industrial, Pharmaceutical, Healthcare, Hospitality and other application filters. Company always focused on providing energy efficient Filtration solutions to enhance productivity, and hence, in 1997 company has entered in a JV with Filtrair BV USA, for having technological upgradation and making available latest technologies to our Indian and overseas

Spear Pack Pvt. Ltd.

Hall No - Hall 4

Booth No - G16

Contact Person - Ravi Shanker

Address - Plot No. 61/G Export Promotion Industrial Park

City - Hyderabad

State - Telangana

Zipcode - 502307

Country - India

Tel - +91 7997997017

Email - exports@spearpack.com

Website - exports@spearpack.com

Exhibitor Profile

Speed Seals Engineering

Hall No - Hall4

Booth No - D20

Contact Person - Ganesh Yadav

Address - Plot No.191(A) Hpsidc Baddi, Distt. solan-173205 H.p Indusytrial Area

City - Solan

State - Himachal Pradesh

Zipcode - 173205

Country - India

Tel - 09817450225

Email - speedseals.engineering@gmail.com

Description -

All Types Of Mechanical Seals,Pumps And Stirrer Manufacturer

Product - Machinery,

Sunny Sterile Products

Hall No - Hall4

Booth No - I22

Contact Person - Viren Shah

Address - 82, Raja Industrial Estate P K Road, Mulund West

City - Mumbai

State - Maharashtra

Zipcode - 400080

Country - India

Tel - 9653393118

Email - sunnysterileproducts@gmail.com

Website - www.sunnyenterprises-india.com

Description -

Clean Room Garments and Consumables

Product - Laboratory Products and Equipments, Clean Room Garments and Consumables,

Swathi Engineering Works

Hall No - Hall4

Booth No - D16

Contact Person - Sarath Das Ambanivas

Address - 215/A, PHASE-III, TSIIC Pashamylaram Medak

City - Hyderabad

State - Telangana

Zipcode - 502307

Country - India

Tel - 9985318034

Email - hepafs@hotmail.com

Website - www.swathicleanrooms.com

Description -

Cleanroom Manufacturers

Product - Clean Room Equipments,

Syntec Airflow Systems

Hall No - Hall4

Booth No - G12

Contact Person - Pinki Verma

Address - Khasra no.4099/31/02, Gali No-3,Surat Nagar, Phase -I, Near DAULTABAD, Block B, Rajendra Park, Sector 105, Gurugram, Haryana 122001

City - Gurugram

State - Haryana

Zipcode - 122001

Country - India

Tel - +91 8130939198

Email - info@syntecair.com

Website - www.syntecair.com

Description -

Syntec Airflow Systems offers a Turnkey solution for Cleanroom and HVAC systems, adhering to various industry standards such as ASHRAE, SMACNA, ISO 14644, BS5295, US FED STD- 209E, EU GMP Guidelines, UK MHRA & WHO GMP. Our expertise covers all aspects, including design, manufacturing, installation, commissioning, and validation of cleanrooms in different classes. We take pride in being the top turnkey service provider for industries such as Healthcare (Pharma, Hospital, Operation theatre, Labs), Food industries, Nutraceuticals, Homeopathic, Ayurvedic, Biotech/Cosmetic sector; Medical device manufacturers (Injection Molding plant/ Orthodontal Manufacturing plant/Surgical items); Agriculture; Electronic companies (Mobile companies/PCB manufacturing plants/Paint shops/Printing industries).

Product - Automation and Robotics, Clean Room Equipments, Consulting services, Filtration / Separation, Laboratory Products and Equipments, Machinery, Plant / Facility Equipments, Regulatory affairs, Validation,

Exhibitor Profile

Technocrats

Hall No - Hall4

Booth No - B17

Contact Person - Sandeep Kadam

Address - D-20, Sainath Ind. Estate Aarey road, Opp Pravasi Ind estate Goregaon East

City - Mumbai

State - Maharashtra

Zipcode - 400063

Country - India

Tel - 9222216703

Email - sandeep@technocratshygiene.com

Website - www.technocratshygiene.com

Description -

Technocrats accepts to convey cutting-edge innovations with the finest possible look and quality. 'One Of The Best Hygiene Products Manufacturing Company'.

Teknokroma India Pvt. Ltd.

Hall No - Hall4

Booth No - F22

Contact Person - Nitin Sharma

Address - 1/6706 A, Ground Floor KH375/581/374 East Rohtash Nagar

City - New Delhi

State - Delhi

Zipcode - 110032

Country - India

Tel - 011-45066584

Email - nitin.sharma@teknokroma.in

Website - www.teknokroma.es

Description -

We are Teknokroma, India, the local subsidiary of a global provider of chromatography technologies and services Teknokroma S.A. Analytica, that advance and accelerate the development and manufacture of Chromatography consumables. Teknokroma is the Barcelona-based world leader in the manufacturer of chromatography media (GC/HPLC columns). Our products are used in the widest array of processes in the pharmaceutical and biotechnology industries.

Product - Filtration / Separation, Instruments, Laboratory Products and Equipments, QA & QC, Validation,

Testo India Private Limited

Contact Person - Gaurav Jha

Hall No - Hall4

Booth No - J08

Address - Plot No.23, Sind Society, Baner Road Aundh

City - Pune

State - Maharashtra

Zipcode - 411007

Country - India

Tel - 020 25920211

Email - gjha@testo.in

Website - www.testo.com

Description -

Testo India Pvt. Ltd. is a 100% subsidiary of Testo SE & Co KGaA, a world leader in design, development and manufacturing of electronic portable test and measuring instruments. Testo India, founded in 2006 with its headquarters in Pune & a PAN India sales network, offers an extensive product range that includes: • Portable Measuring Instruments & Systems for: Temperature, Humidity, Dew point, Pressure, Air velocity, RPM, Sound, Light, Compressed Air Flow, Electrical Measurement • Data Loggers and Wireless Data Monitoring System • Portable Flue Gas Analyzers for Combustion and Emission Analysis • Thermal Imagers for Predictive & Preventive Maintenance

Product - Instruments, Laboratory Products and Equipments,

Thaletec GmbH

Contact persons: Europe- Alexander Barkow

India - Vaibhav Gokhale

Address: Steinbachstraße 3 | D-06502 Thale, Germany

Tel.: +49 (0) 3947-778 0 | Telefax: +49 (0) 3947 778 110, +91 96871 00080

E-Mail: sales@thaletec.com, vaibhv.gokhale@thaletec.in

Website: <http://www.thaletec.com/>

Thaletec GmbH is 100% subsidiarily owned by HLE Glascoat.

Products: Glass lined Reactors, Tanks, Agitators, Columns, Glass lined Heat Exchangers.

Exhibitor Profile

Thermadyne Private Limited

Hall No - Hall 4

Booth No - K12

Contact Person - Deepak M.S. Saluja

Address - 24th Km (14/5 Miles) Mathura Road

City - FARIDABAD

State - HARYANA

Zipcode - 121003

Country - India

Tel - 0129-2258877 / 2258818

Fax - 2275418

Email - e.mail@thermadyne.co.in

Website - www.thermadyne.co.in

Description -

THERMADYNE, a pivotal member of the CDIL group headquartered in Faridabad, leads the charge in air filtration excellence with a notable group turnover of 50 million USD. Renowned for pioneering Laminar Flow Clean Air commercially in India five decades ago, THERMADYNE stands as a symbol of unwavering commitment. Specializing in manufacturing world-class Air Filters and Clean Room equipments, our products serve diverse industrial and governmental needs nationwide. With a relentless focus on design, production, and rigorous testing, THERMADYNE remains at the forefront of innovation, ensuring a legacy of clean air solutions that redefine industry standards.

Product - Clean Room Equipments, Filtration / Separation, Laboratory Products and Equipments, Testing and Measurement, Validation,

Third Wave Ruggedtech Pvt. Ltd.

Hall No - hall 4

Booth No - D15

Contact Person - Meghal Desai

Address - Basemnet, 4, Chaitanya, Opp. Mardia Plaza, C.g. Road

City - AHMEDABAD

State - Gujarat

Zipcode - 380006

Country - India

Email - info@thirdwaveruggedtech.com

Description -

Third Wave specializes in rugged computing solutions tailored for the pharmaceutical industry, leveraging over two decades of expertise. Our innovative mobile computing solutions are designed to withstand extreme environments, ensuring uninterrupted operations in pharmaceutical environment. With a deep understanding of the industry's unique requirements, Third Wave delivers reliable and efficient technology hardware solutions that enhance productivity and streamline processes for pharmaceutical companies.

Product - Automation and Robotics, Instruments, Industrial Rugged Tablet & Laptop for Pharmaceutical Environment,

Exhibitor Profile

Topse Process Solutions Pvt. Ltd.

Hall No - Hall4

Booth No - G15

Contact Person - Santosh Sadavare

Address - Plot No. 48A, Hill Top Society, Dhankawadi, Pune

City - Pune

State - Maharashtra

Zipcode - 411043

Country - India

Tel - 7720039828

Email - marketing@topse.in

Website - www.topse.in

Description -

Topse has highly experienced team of 120 Engineers & Equipped with Engineering softwares such as Solid Works and Solid Plant-3D to cater to Client's needs most professionally. Our Turnkey Project delivery includes Design, Engineering, Supply, Installation and Commissioning as well as Training and Skill Development. In house facility for Design, Engineering and Manufacturing of all types of Mechanical Equipments such as Stainless Steel Reactors, Process Vessels, Storage Tanks, Distillation Columns, Condensers, Reboilers, Evaporators, Solvent Recovery Units, Heating and Cooling System and Hydrogenators. As well as having 20 years of experience in the field of Electrical, Control and Automation Systems.

Product - Active Pharmaceutical Ingredients, Alkaloids, Amino acids, Analytical Equipments, Antibiotics, Antibodies, Antimicrobial preservatives, Antioxidants, Automation and Robotics, Batching Systems / Equipments, Biocatalysts, Biochemicals, Bioinformatics, Biotechnology, Capsules / encapsulation, Chemical synthesis / analysis, Chiral intermediates, Colour and dispersions, Computer software, Consulting services, Contract Research, Contract Services, Emulsifying / solubilising agents, Enzymes, Excipients and Drug formulation, Filling Equipments, Filtration / Separation, Fine chemicals, Flavours and perfumes, Glidants, Instruments, Intermediates, Laboratory Products and Equipments, Life Sciences, Machinery, Medicinal plants, Microencapsulation, Ointments bases, Packaging Equipment & Supplies, Peptides, Phospholipids, Plant / animal extracts, Plant / Facility Equipments, Process Automation & Controls, Processing Equipment's, Purification and separation techniques, Solvents, Sweetening agents, Synthetic organic chemistry,

UD Pharma Rubber Products

Hall No - Hall4

Booth No - F19

Contact Person - D.H. Verma

Address - R 58/1, TTC Industrial Area, MIDC, Rabale, NaviMumbai,

City - MUMBAI

State - Maharashtra

Zipcode - 400701

Country - India

Tel - 022 27696262

Email - dverma64@yahoo.co.in

Website - www.udpharmaproducts.com

Description -

Pharma Packaging material-Dropper Assembly, Measuring cup, Cap, Bottle, Effervescent tube, dessicant cap, Rubber Stopper, Cosmetics dropper, Glass bottle and many more

Product - Pharma Packaging material-Dropper Assembly, Measuring cup, Cap, Bottle, Effervescent tube, dessicant cap,

Ultramax Hydrojet Pvt. Ltd.

Hall No - Hall4

Booth No - D22

Contact Person - B K Poovarasan

Address - Plot No 31/4a 6th Main Road Sidco Industrial Estate Thirumudivakkam

City - CHENNAI

State - Tamil Nadu

Zipcode - 600044

Country - India

Tel - 044-42852262 / 64

Email - marketing@hydrojet.co.in

Website - www.hydrojet.co.in

Description -

Ultramax hydrojet pvt. Ltd. Is widely acknowledged as one of the leading manufacturer and exporter of custom made industrial cleaning equipment for various industries like, automobile, Pharma, food, engineering, railway and many more. Our AHU Pre filter Cleaning machine are widely used in industry were facing tough cleaning & drying challenge. All first time customer becomes repeated customer shows the extent of

Exhibitor Profile

customer Quality Product & Service satisfaction, With very good after sales support. Few of the customers are Mylan Laboratories Ltd Cipla Ltd Mankind Pharma RRSPL Sun Pharmaceuticals Ltd Natco Pharma Ltd Hetero Labs Laurus Labs AET

Product - Clean Room Equipments, Custom manufacturing, Machinery, Processing Equipment's,

Veolia Water Technologies and Solutions

Hall No - Hall4

Booth No - C20

Contact Person - Sunitha Dishan

Address - 3rd Floor RMZ, Block 2A No 302, Campus 2A, Building, Whitefield Rd, Sonnenahalli

City - Bengaluru

State - Karnataka

Zipcode - 560066

Country - India

Tel - +91 9731177044

Email - sunitha.dishan@veolia.com

Website - www.veolia.com

Description -

Veolia, as the world's foremost environmental solutions provider, specializes in cutting-edge technologies for water and wastewater treatment, recycling solutions, High Purity Water for WFI and Zero Liquid Discharge initiatives. We also offer a comprehensive range of technology-manufactured products crucial for project implementations, including membranes, chemicals, and filters. With a track record of serving over 200 esteemed organizations in India and being a Fortune 500 company, we take immense pride in our ability to deliver satisfaction and tangible results to our valued clients.

Product - Water and Wastewater Treatment, ZLD, Purified Water/WFI, Plant / Facility Equipments,

Vijay Rubber Products

Hall No - Hall4

Booth No - J19

Contact Person - Dhruvin Shah

Address - Plot No. 40, Survey No. 984, Ambika Udyog Nagar, Old Satpati Road, Vill- Shirgaon

City - Palghar

State - Maharashtra

Zipcode - 401404

Country - India

Tel - 9082793048

Email - accounts@vijayrubberproducts.co.in

Website - www.vijayrubberproducts.co.in

Description -

Vijay Rubber Products an ISO 9001-2015 certified company located in Mumbai (Maharashtra) and are engaged in manufacturing and supplying premium quality moulded & extruded rubber parts like bellows, diaphragms, extrusion profiles, mechanical seals & O rings and silicone rubber components. We have a modernized manufacturing plant equipped with machinery that guarantees precision moulded rubber components, which are widely used in various industrial applications. Our comprehensive product range of oil seals, bellows, silicon tubes, neoprene and silicon parts etc. allows our clients to have a technological solution, which is precisely tailored to their manufacturing requirements.

Product - moulded & extruded rubber parts like bellows, diaphragms, extrusion profiles, mechanical seals & O r,

Vorx Industrial Solutions

Contact Person - AKSHATA BAGWE

Hall No - Hall4

Booth No - M20

Address - A-206 Byculla Service Industries D.K marg, Byculla (East)

City - Mumbai

State - Maharashtra

Zipcode - 400027

Country - India

Tel - 9820333120

Email - cs@vorxindustrial.com

Website - www.vorxindustrial.com

Description -

Epoxy Flooring

Product - EPOXY FLOORING SAMPLES,

Exhibitor Profile

X2 Valves Pvt. Ltd.

Hall No - Hall4

Booth No - I08

Contact Person - Anil Bhalu

Address - Survey No.980/1, B/H Rangani Engineering, Captain Gate, Shapar (Veraval), Dist. Rajkot -360 024

City - Rajkot

State - Gujarat

Zipcode - 360024

Country - India

Tel - +91 87992 45553

Email - info@x2valves.in

Website - www.x2valves.in

Description -

To explore cutting-edge innovations in pharmaceuticals, biotechnology, and analytical techniques. Engage with industry leaders and discover the latest advancements in drug development, manufacturing, and quality control. Connect with suppliers of laboratory equipment, instrumentation, and regulatory compliance solutions. Attend insightful seminars and workshops on topics ranging from chromatography to spectroscopy. Network with professionals from across the globe and forge valuable partnerships. Whether you're a researcher, scientist, or industry professional, Pharmalytica offers unparalleled opportunities for knowledge exchange and collaboration. Join us in shaping the future of healthcare through science and technology.

Product - Automation and Robotics, Instruments, Machinery, Plant / Facility Equipments, Process Automation & Controls, Processing Equipment's,

Yogi Kripa Steriprotek Packaging Pvt. Ltd.

Hall No - Hall 4

Booth No - M15

Contact Person - kamlesh thakkar

Address - Unit No.101-103,Ujagar Chambers, plot 2E Sunder Baug, off Sion Trombay

City - Mumbai

State - Maharashtra

Zipcode - 400088

Country - India

Tel - 9323104221

Email - kamlesh.thakkar@yogikripa.com

Website - www.yogikripa.com

Description -

Revolutionizing Sterilization Reels for a Safer World! At Steriprotek, we believe that every sterile procedure deserves the highest level of protection. With a passion for innovation and a commitment to excellence, we are proud to introduce our groundbreaking sterilization reels that redefine safety standards in the medical industry. We are proud to serve a diverse range of medical facilities including pharmaceutical manufacturing (vaccines and injectable), medical device manufacturing and hospitals and nursing homes. Join us on this groundbreaking journey as we revolutionize sterilization practices and pave the way for a safer, more secure medical industry.

Product - Custom manufacturing, Packaging Equipment & Supplies,



COMPLIANCE MADE EASY

**“YOUR ONE STOP
SOLUTION IN THE
VALIDATION INDUSTRY”**



OUR SERVICES:

- ✓ CONSULTING
- ✓ FACILITY DESIGN
- ✓ BUILDING FACILITY
- ✓ EQUIPMENT PROCUREMENT
- ✓ COMMISSION & QUALIFICATION
- ✓ AUTOMATION & CSV
- ✓ CALIBRATION
- ✓ THERMAL VALIDATION
- ✓ CLEANROOM VALIDATION
- ✓ CIP/SIP VALIDATION
- ✓ GMP & COMPLIANCE

**VISIT US AT
J22**

Contact us :

 +91-63669-42391

 www.incepbio.com





MORESCHI
DOORS
SAFE & SECURE

✉ : doors@moreschiasia.com
☎ : +91 7032820763,8978388005

🌐 : www.moreschisrl.com

First European Company To Manufacture Industrial Doors In India



FOLDING DOOR



SLIDING DOOR



SPEED ROLL UP DOOR



INSULATED ROLLING SHUTTER
WITH DOCK LEVELLER
& DOCK SHELTER



SPEED ROLL UP DOOR

**Leader in Manufacturing Insulated Doors for the
Warehouses, Automobile, Food, Aeronautical, Logistics and Pharmaceutical Industries etc.**

Moreschi Asia Assures You

- Quality with Performance & Convenience
- Appearance with Specialized & Specific Operational Solutions

Moreschi Asia Doors is a wholly-owned subsidiary of Moreschi Srl, Italy, a leading provider of Industrial Doors.

We specialize in the Design, Manufacturing & Installation of various types of doors:

Folding Doors, Sliding Doors, Speed Roll-Up Doors, Insulated & Single-Skin Rolling Shutters,
Steel Doors, Dock Levelers & Shelters with modern technology.

Moreschi Doors Located in Hyderabad, operates with modern technology to cater
to the needs of the Indian and Asian markets having a State-of-the-Art Manufacturing Facility.

Moreschi Asia Doors Pvt. Ltd.

Plot No:6, IDA Bollaram, Near Miyapur, Hyderabad-502325, Telangana, India.

Tel No : +91.7032 820 763, 8978388005.

Email : doors@moreschiasia.com, Website: www.moreschisrl.com



Surface Measurement Systems
World Leader in Sorption Science

The world's leading gravimetric sorption analyzers for advanced materials characterization



- Sorption Isotherms & Kinetics
- Hygroscopicity
- Crystallinity
- Glass Transition Humidity
- Amorphous Content
- Diffusion
- Polymorphs
- Stability
- Surface Area
- Solubility
- Flowability
- Porosity

Visit us on stand **B22**

www.surfacemeasurementsystems.com

Office locations:

UK • USA • India • Germany • China

THERMADYNE

PVT. LTD.

CLEAN AIR SYSTEMS

Thermadyne, headquartered in Faridabad, is a prominent member of the CDIL group, boasting a substantial group turnover of 50 million USD. Our company stands as a beacon of reliability, specializing in the manufacture of world-class air filters and laminar flow equipment designed for a myriad of applications across India. We proudly hold the distinction of being the inaugural Indian manufacturer to introduce the revolutionary concept of Laminar Flow Clean Air on a commercial scale five decades ago. Ever since that pivotal moment, we have remained steadfast in our commitment to the design, production, and rigorous testing of air filters, filtration systems, and clean air equipment. Our products are in active service throughout the country, catering to the diverse needs of industrial and governmental organizations.



◆ PRODUCTS

AIR FILTERS

- PRE FILTER
- FINE FILTER
- HEPA FILTER
- MINI PLEAT
- ULPA FILTER
- CHEMICAL FILTER
- OTHERS

CLEAN ROOM EQUIPMENTS

- AIR SHOWER
- LAMINAR FLOW BENCHES
- BIO SAFETY CABINET
- FFU
- GEL SEAL HOUSING
- DISPENSING STATIONS
- PASSBOXES
- OTHERS

Thermadyne Private Limited
 24TH KM (14/5 Mile Stone), Mathura Road, Faridabad-121003
 (Haryana) INDIA
 Phone :- +91 - 129 - 2258818, 2250626, 2258877,
 2275708, 09 Fax:- +91 - 129 - 2275418
 E-Mail:- email@thermadyne.co.in,
 Website:- www.thermadyne.co.in

Hygro Tech Engineers is an Application Environment Specialist in Humidity control with extensive range of products and services that help our customers achieve their performance and production Goals. Hygro Tech Engineers arrived to treat moisture problems involved in air control and stimulation to sustain the desired Environment



DEHUMIDIFIED AIR HANDLING UNIT



CUSTOMIZED DESICCANT DEHUMIDIFIER



ENGINEERED DESICCANT DEHUMIDIFIER

HYGRO PROVIDES SOLUTION FOR,

- Corrosion Prevention
- Condensation Protection
- Fungus Protection
- Product Drying
- Low Temperature Drying

Product Drying Lab Facility Available at Hygro R & D Center

Hygro Products

- Desiccant Dehumidifier
- Dehumidified Air Handling Unit
- Dry Rooms for Lithium Battery Manufacturing
- Seed Box Dryer
- Seed Drum Dryer
- Battery Plate curing and Drying Chambers
- Industrial Ovens
- Product Drying Chambers
- Wood Drying Kilns

Applications



**COMPACT DEHUMIDIFIER
VERTICAL / HORIZONTAL**

Other Applications



HYGRO TECH ENGINEERS

No.61 & 62 Kachohalli gate, Magadi Main Road, Behind Rajarajeshwari Kalyana Mantapa, Bangalore, Karnataka - 560091

E-mail: sales@hygrotechindia.com Mobile No: +91 9886144100 Tel No: +91 80 29776001 / 02 Website: www.hygrotechindia.com



WHY INFIONIC?

**Domain Expertise | Affordability
Ease of Use | Proven Record
Mobile Enabled**

Enhancing
**Compliance
& Productivity**
through
Digitization

KEY FEATURES

CFR Part 11 Compliant

Granular User permissions

Comprehensive Reports

Dashboards and Analytics

SOLUTIONS

DOMINO

Integrated project portfolio
management solution

SYNC

The smart supply chain
solution to manage material

JOURNAL

State-of-art electronic lab
notebook

CRM

Customer relationship
management solution to
empower sales force

HRM

The ultimate solution to
manage human resources

R & D

Helping innovators succeed
through technology

USA

405 Lexington Avenue
New York NY 10174

INDIA

4th Floor, Sanali Spazio
Inorbit Mall Road Madha-
pur, Hyderabad - 500081

sales@infionic.com

www.infionic.com



Tailormade **ERP** suite for SME'S
which is CFR part 11 complaint

- * Inventory & material management
- * Procurement & quality control
- * Manufacturing Operations including asset management
- * Sale order & dispatch management
- * Finance & accounting



Comprehensive CFR part 11 complaint
Document Management System

- * Document management from creation to making obsolete
- * Document issue/print & reconciliation
- * GMP compliance including change controls and training mandates
- * Print, audit history & tracking
- * Digital archives for easy retrieval



Configure CFR part 11 complaint
Quality Management System

- * Change control and CAPA management
- * Deviations, OOT & OOS management
- * Audit management
- * Training management
- * Quality summary reports

We dry spaces.
Since 1998.



origin

High Performance Portable De-humidifiers
Over 15,000+ Installations. Since 1998.

om 50

Strong Metal Body. High Air Flow

TOPSE PROCESS SOLUTIONS PVT.LTD. PUNE

TOPSE Process Solutions Pvt Ltd is pioneer in Turnkey projects including Design and Engineering, Procurement, Manufacturing, Construction and Commissioning for Active Pharmaceutical Ingredient (API), Biopharmaceuticals, Speciality & Fine Chemical industries achieving highest regulatory compliance.

TOPSE has experienced and professional team of 150+ multi-disciplinary engineers having specialization in Chemical, Mechanical, Instrumentation and Control, Electrical, Civil & Mechanical Piping.

TOPSE has in-house capability for Design, Manufacturing, and Supply of all types of Mechanical Equipments such as Stainless Steel Reactors, Pressure Vessels, Distillation Systems, Evaporators, Solvent Recovery Units, Heating and Cooling System. As well as complete turnkey supply of Electrical, Field Instrumentation and Automation systems for all the process industries.

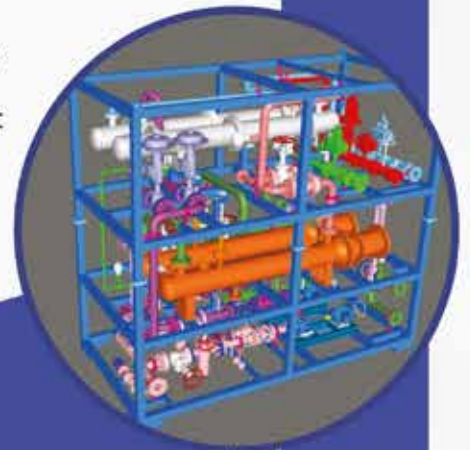

TECHNOLOGIES

✓ Single Fluid heating and cooling system

Semiautomatic /fully automatic through PLC /Centralized DCS

✓ Distillation Systems

Atom. Distillation & High vacuum distillation up to 1 Torr.

✓ Solvent Extraction Plant

Turnkey process solution for Herbal and oil seed extraction

✓ Evaporation Systems

RFE, FFE, FCE, ATFE

✓ Solvent Dehydration Systems

PSA, TSA, Pervaporation and Vapor Permeation Membrane system for OPEX reduction

✓ Turnkey Process Plant

Design, Engineering, Manufacturing, Supply & Execution of Process Equipment, Electrical & Automation



CONTACT US :-

 www.topse.in

 marketing@topse.in



AS AUTOMATIONS

Automation in Pharma Packaging

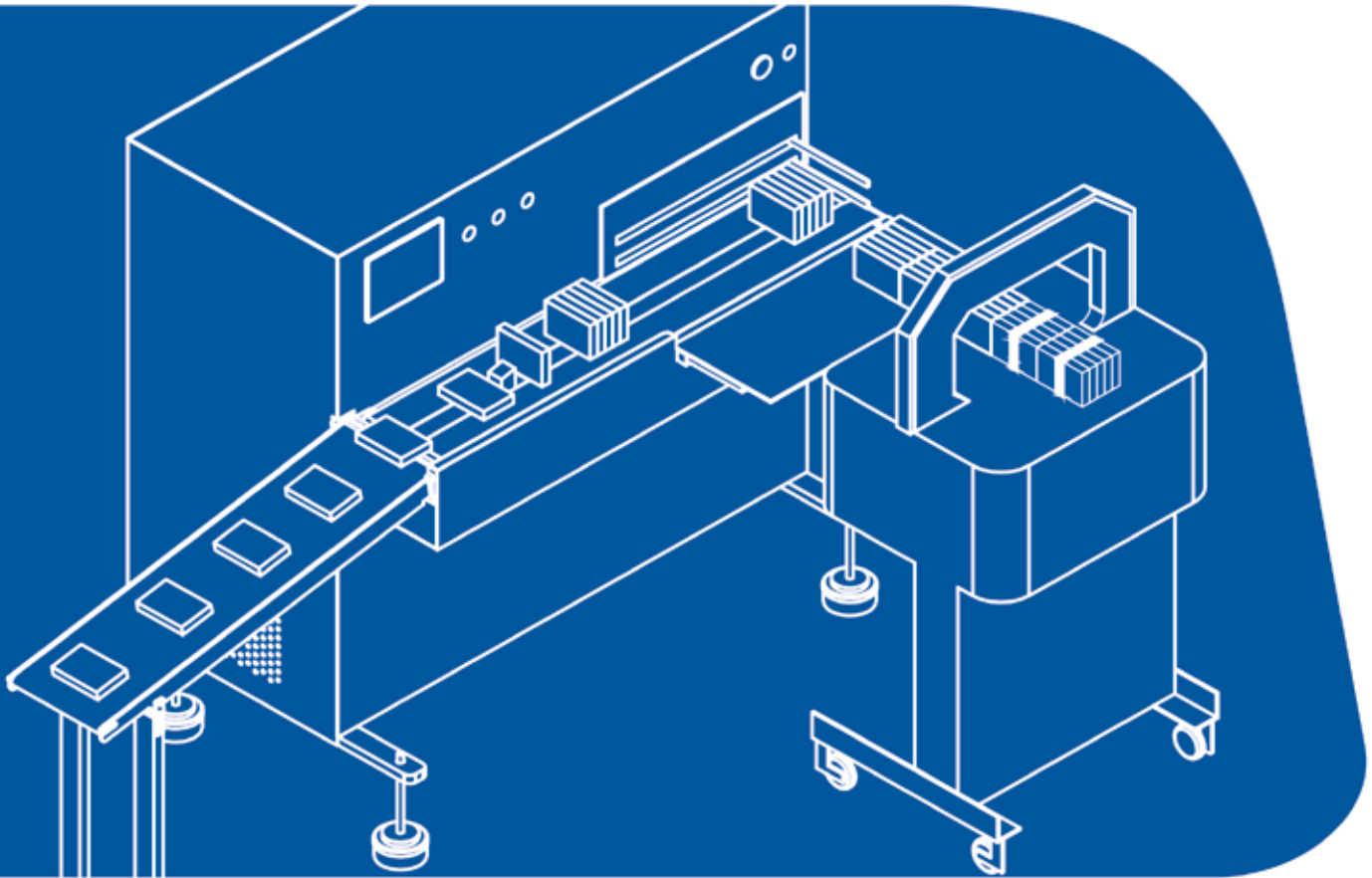

Automation In

Secondary
Packaging



Blister
Packaging



Strip
Packaging



Sachet
Packaging



Scan for Website



Plot No. 122, Sector 7, Vishweshwar Chowk,
Bhosari, Pune - 411026. Maharashtra, INDIA



asautomations@yahoo.com



Office : +91 8329258283



Mobile : +91 9890198565 | +91 7875108888



www.asautomations.com



SOLUTION FOR EXCELLENCE

MRB FORGE & FITTINGS LLP.

Manufacturer & Exporter:

MRB Forge & Fittings LLP. stands as the epitome of rapid growth and excellence in manufacturing within Gujarat, India. With prestigious certifications such as ISO 9001-2015 and PED Certified by TUV-NORD, along with being an IBR-Approved Manufacturing Co., we offer unparalleled quality and reliability in our products and services.

At MRB, we don't just deliver piping products; we provide solutions that surpass your expectations. Trust us to meet and exceed your needs, and experience the difference with MRB.

Product Portfolio

Pipes, Pipe Fittings, Flanges, L-SAW
Pipes in grades of Stainless Steel,
Carbon Steel, Duplex Steel, Etc.





Scientific Devices
(Bombay) Pvt. Ltd.

ABOUT US

We are **AN ISO 9001:2015, 14001 : 2004, CE Certified, DNV Type Approved, NABL Accredited, ATEX and IBR Certified** Company engaged in Designing, Manufacturing and Supply of Flow, Level, Temperature, Pressure Measurement And Control Instruments, Sight Glasses, Breather Valve, Flame Arrestor And Pipe Line Strainers since past 30 years used for Chemical Process, Petrochemicals, Power generation, Oil & Gas, Pharmaceutical, Ship building, steel, water and waste water treatment plants and Cement Industries etc.



CONTACT US



+91 773 88 94 716 | 771 58 14 717



Sales@scientificdevices.org



www.scientificdevices.org

HEAD OFFICE

Office no. 53, Shree Manoshi Complex, Plot No. 5 & 6, Sector 3, Opp., Ghansoli Railway Station, Ghansoli (East), Navi Mumbai-400701, Maharashtra. INDIA.

WORK I

Scientific Center, At By-pass junction, Near Kalsekar College, Kausa, Mumbra, Thane - 400612. Maharashtra, INDIA.

WORK II

Scientific Complex, Opp. Thakurpada, Mahapa Road, Post Padle Village, Near Shil Octroi Naka, Mumbra, Thane 421 204, Maharashtra, INDIA

Be sure.



Needed: Precise data loggers for critical jobs.

Found: Testo data loggers for Pharma



Data loggers from Testo: Precision in every application.



testo 174T



testo 175H1



testo Saveris 2



testo 176 T1



testo 184-T3



testo 160

• **testo 174T: Mini temp. data logger**

- IP 65, HACCP-compliant, 500 days of battery life.
- Measuring accuracy of ± 0.5 °C
- Measurement data memory for 16,000 readings

• **testo 175H1: Temp. and %rH logger**

- Continuous monitoring & logging of temperature, relative humidity and dew point
- External humidity probe for extra fast response
- Up to 1 million readings, battery life of 3 years

• **testo Saveris 2: Wi-Fi data logger**

- Reliable solution to humidity and temperature monitoring in cold storage, work rooms etc.
- Secure online storage of readings in Testo Cloud
- Alerts when limit values are exceeded

• **testo 176 T1: Temp. Data loggers**

- High-precision Pt100 temperature sensor
- Sturdy, EN 12830 certified & HACCP-compliant
- Memory for up to 2 million readings

• **testo 184-T3: Transport data logger**

- Monitor the transport of sensitive products, such as pharmaceuticals, food or electronic items
- Easily accommodated even in confined spaces
- Compliant with GxP, 21 CFR Part 11, HACCP and EN 12830

• **testo 160: Wi-Fi data logger**

- Ideal for monitoring indoor air quality (IAQ)
- testo 160 data loggers can monitor CO_2 , humidity, temperature, atmospheric pressure, illuminance, UV radiation.

Testo India Pvt Ltd

+91 20 2592 0000



info@testo.in



Designed in GERMANY

www.testo.com

Getac

DEVICES THAT WITHSTAND HAZARDOUS ENVIRONMENTS AND STERILIZATION



Pharmaceutical companies use tablets and other devices in clean room environments, for clean room applications which are designed to minimize contaminants like dust, microbes, and particles. These are crucial in the production, testing, and packaging of drugs and medical devices, as well as for R&D work.

Since tablets are widely used for inventory control, research, quality control, etc., it is imperative that they are duly certified and meet the applicable standards for these environments.



Getac's specialist devices (e.g. the UX10-IP rugged tablet) feature sealed buttons to allow frequent cleaning, preventing infection and cross-contamination. They meet ANSI (American National Standards Institute) safety standards, for use in potentially hazardous environments such as labs.

For more details on Getac pharma-compatible devices and demos, get in touch with authorized distributors Third Wave Rugged today!

THIRD WAVE

RUGGED | RELIABLE

info@thirdwaveruggedtech.com

www.thirdwaverugged.com

AHMEDABAD | BENGALURU | CHENNAI | DELHI | HYDERABAD | PUNE



PharmCrux

Committed to Assure Compliance

ONE STOP FOR ALL GXP SOLUTIONS

eGMP Consultancy
eGMP GAP Assessment
Quality remediation
QMS Life cycle Management
Product Life Cycle management
Preparation for Regulatory Inspections
Training.

Consultancy

Regulatory Services

US Agent services
Application Fillings
- API
- Intermediate
- Drug Product
- Excipients
Application life cycle management
Firm registrations across the globe.

Our Services

Third Party Audits
Internal Audits
Pre-inspection Audit

Auditing

eSolutions

Applications available for demo :

- Learning Management systems (LMS)
- Quality Management System (QMS)
- Document Management System (DMS)
- eNotes (eLog), -Material Management Stability, -eLab
- Customer Relationship Management (CRM)
- Application compliance status:
- 21 CFR part 11, EU Annex 11 & GAMP5 compliance
- Compacte with Android and iOS devices.

Projects & Validations

eGMP Turnkey projects
Design of manufacturing plants
- API's and formulations.
Computer system validations

High Technical capabilities in building eGMP & Software Applications for Pharmaceutical industry

Contact: P. Venkatapathi Raju , Mobile : 9000624456, Website: www.pharmcrux.com

Title Partner



Be part of India's vibrant nutraceutical event

Connect with thousands of key players in this thriving market

5 – 7 February 2025, Mumbai, India



8000+
attendees



150+
exhibitors



40+
countries



93%
visitors source
and meet with
suppliers



COSMOPROF

INDIA MUMBAI

• THE NOT TO BE MISSED EVENT
FOR THE ENTIRE BEAUTY
BUSINESS COMMUNITY IN INDIA

• **MUMBAI**

JIO WORLD CONVENTION CENTRE

• **5 - 7 DECEMBER 2024**

COSMOPROF INDIA

COSMOPACK INDIA

• COSMOPROFINDIA.COM

Heads Collective

Organized by Cosmoprof India Private Limited



informa markets

A new world for beauty

Bologna, Hong Kong,
Las Vegas, Mumbai,
Bangkok, Miami



India

25-27 September 2024
BIEC, Bengaluru



Tomorrow's Taste Today

Fi India, Your One-Stop Destination for Food & Beverage Solutions!



Book Your Stand



Fi India 2024 is a must-attend event for those aiming to grow their presence in India's dynamic food and beverage market.

Embark on a journey of flavors and opportunities



Enhance your lead generation



Engage with industry innovators driving change



Discover food trends on a global scale



Be among the taste makers of tomorrow

Come and be a part of the 18th edition of the Fi India exhibition.

FOR SPACE BOOKING:

Archana Shinde
+91 97696 65065
archana.shinde@informa.com

Sandip Chalke
+91 84249 25443
Sandip.Chalke@informa.com

FOR MARKETING & ALLIANCES:

Priyanka Vaidya
+91 99677 67225
priyanka.vaidya@informa.com

www.fi-india.com



Follow us on: @fhi2020 @Fi India @FiIndia_2006

Experience the Progressive Changes in the Processing and Packaging Industry

#PackedWithSuccess

ProPak India is a part of the international ProPak exhibition series and India's prominent business gathering in the processing and packaging industry.

ProPak India: Where innovation breaks barriers.

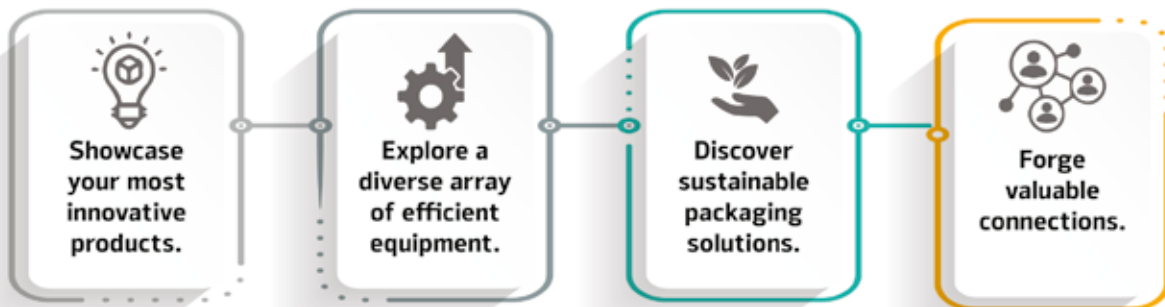

Need more information? We're here to help!

For Space Booking

Mehraj Waghu | M: +91 98202 09795

E: mehraj.waghu@informa.com

Mustaque Ahmed | M: +91 98193 48505

E: mustaque.ahmed@informa.com

For Marketing & Alliances

Priyanka Vaidya | M: +91 9967767225

E: priyanka.vaidya@informa.com

Book Your Booth Today!



co-located with



www.propakindia.com



@ProPakIN



@propak-india



@propak.india



SURRAVI PHHARMA

Empty Capsules Distributor cum Channel Partners

(Available Empty Capsules, Raw Materials, Oils, Phosphates, Colours & Vitamins)

EMPTY CAPSULES :-

- ◆ Available Empty HPMC Vegetarian Capsules
- ◆ Available Empty Gelatin Capsules
- ◆ Empty capsules ready stocks available in all sizes with customized color Options
- ◆ Capsules manufactured at USFDA approved Plant
- ◆ Maintaining in Centralised Air Conditioned GMP warehouse



Contact: 8008002576 | Email: surraviphharma@rediffmail.com



CPHI

India

PMEC

India

26- 28 November 2024 | India Expo Center, Greater Noida, Delhi NCR



South Asia's largest pharma event

One venue, over 50,000 professionals, endless opportunities! CPHI & PMEC India offers unlimited opportunities! It's the ultimate platform to expand your business, amplify visibility, forge invaluable connections, and generate top-notch leads in India and beyond.



50,000+
Attendees



120+
Attendee countries



1800+
Exhibiting companies



120,000+
m²

Contact

For Partnership Opportunities:

CPHI: Shruti Save | E: shruti.save@informa.com

PMEC: Sameer Matkar | E: sameer.matkar@informa.com

For Marketing Opportunities:

Dheeresh Bangera | E: dheeresh.bangera@informa.com

Mahesh Verma | E: mahesh.verma@informa.com

International enquiries:

salesoperations@informa.com





HOW TO REACH HITEX EXHIBITION CENTRE

Enjoy the Convenience of Our
Free Bus Shuttle Services for All Three Days

Route 1

Pickup Point	Jeedimetla Industrial Association office	09:00 AM
Stop 1	Balanagar Bus Stop	09:25 AM
Stop 2	Mosapet Y Junction Road Towards Mumbai Highway	09:45 AM
Stop 3	Kukatpally Metro Station	10:00 AM
Stop 4	JNTU College	10:15 AM
Stop 5	Hitex Charminar Gate	10:35 AM
Drop Point	Hitex Exhibition Centre	10:40 AM

Route 2

Pickup Point	Nacharam Industria Association Office	09:00 AM
Stop 1	Secunderabad Railway Station	09:30 AM
Stop 2	Begumpet Bus Stop	09:45 AM
Stop 3	Panjagutta Circle	10:00 AM
Stop 4	Hotel Radisson Blu Plaza, Banjara Hills	10:20 AM
Stop 5	Jubile Hills Metro station	10:45 AM
Stop 6	Hitex Charminar Gate	10:50 AM
Drop Point	Hitex Exhibition Centre	11:00 AM

Route 3

Pickup Point	MGBS Bus Stand	09:00 AM
Stop 1	Nampally Railway Station	09:30 AM
Stop 2	Mehdipatnam Bus Station	09:45 AM
Stop 3	Shah Ghouse Hotel Gachibowli Road	10:00 AM
Stop 4	Shilparamam Park Hitex City	10:30 AM
Stop 5	Hitex Charminar Gate	10:40 AM
Drop Point	Hitex Exhibition Centre	10:40 AM

Route 4

Pickup Point	HITEC City Metro Station	09:00 AM
Stop 1	Hitex Charminar Gate	09:15 AM
Drop Point	Hitex Exhibition Centre	10:40 AM

Route 5

Pickup Point	Hitex Charminar Gate	 Continuous Running
Drop Point	Hitex Exhibition Centre	

30 May - 1 June 2024
HITEX, Hyderabad

A DECADE OF INNOVATION
A Legacy of Excellence

Thank You Partners

Sustainability Partner



Supporting Partners



TELANGANA LIFE SCIENCES

E-mobility Partner



Association Partners



Media Partners

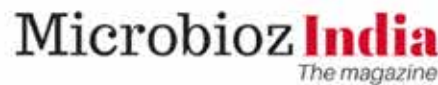



SEE YOU NEXT YEAR!

in the pharma capital of **India**

29 - 31 May 2025

Hitex, Hyderabad

FOR STAND BOOKINGS & PARTNERSHIPS

DEVENDRA BHOSALE

E: devendra.bhosale@informa.com | M: +91 84335 04446

JATIN LAD

E: jatin.lad@informa.com | M: +91 98700 74249

FOR MARKETING & MEDIA PARTNERSHIPS

DHEERESH BANGERA

E: dheeresh.bangera@informa.com | M: +91 90040 21880

MAHESH VERMA

E: mahesh.verma@informa.com | M: +91 74989 67629